



CX1140

HYDROGEN THYRATRON

Service Type CV8563

The data to be read in conjunction with the Hydrogen Thyatron Preamble.

ABRIDGED DATA

Hydrogen-filled tetrode thyatron, featuring low jitter and low anode delay time drift. Suitable for use at high pulse repetition rates, in parallel for switching higher powers, or for switching long pulses. A reservoir operating from the cathode heater supply is incorporated. The CX1140 replaces many less sophisticated thyatrons of similar rating when used with base adaptors obtainable from EEV. Details of these adaptors are given on page 5.

Peak forward anode voltage	25	kV max
Peak anode current (see page 2)	1000	A max
Average anode current	1.25	A max
Anode heating factor	9.0×10^9	V.A.p.p.s. max
Peak output power	12.5	MW max

GENERAL

Electrical

Cathode (connected internally to mid-point of heater)		oxide coated
Heater voltage	$6.3 \pm 5\%$	V
Heater current	22	A
Tube heating time (minimum)	5.0	min
Inter-electrode capacitances (approximate):		
anode to grid 2 (grid 1 and cathode not connected)	13	pF
anode to grid 1 (grid 2 and cathode not connected)	7.5	pF
anode to cathode (grid 1 and grid 2 not connected)	26	pF

Mechanical

Overall length	12.500 inches (317.5mm) max
Overall diameter	3.312 inches (84.12mm) max
Net weight	1½ pounds (0.7kg) approx
Mounting position (see note 1)	any
Base	pin spacing as B5F; metal shell with micalex insert
Top cap (see note 2)	B.S.448-CT3

Cooling	natural
---------	---------

PULSE MODULATOR SERVICE

MAXIMUM AND MINIMUM RATINGS (Absolute values)

	Min	Max	
Anode			
Peak forward anode voltage (see note 3)	—	25	kV
Peak inverse anode voltage (see note 4)	—	25	kV
Peak anode current	—	1000	A
Peak anode current (pulse repetition rate limited to 60p.p.s. max)	—	2000	A
Average anode current	—	1.25	A
Rate of rise of anode current (see note 5)	—	5000	A/ μ s
Anode heating factor	—	9.0×10^9	V.A.p.p.s.

Grid 2

Unloaded grid 2 drive pulse voltage (see note 6)	200	1000	V
Grid 2 pulse duration	1.0	—	μ s
Rate of rise of grid 2 pulse (see note 5)	1.0	—	kV/ μ s
Grid 2 pulse delay	0.5	3.0	μ s
Peak inverse grid 2 voltage	—	450	V
Loaded grid 2 bias voltage	-50	-150	V
Forward impedance of grid 2 drive circuit	50	800	Ω

Grid 1 — D.C. Primed (See note 7)

D.C. grid 1 unloaded priming voltage	75	150	V
D.C. grid 1 priming current	50	100	mA

Grid 1 — Pulsed

Unloaded grid 1 drive pulse voltage (see note 6)	300	1000	V
Grid 1 pulse duration	2.0	—	μ s
Rate of rise of grid 1 pulse (see note 5)	1.0	—	kV/ μ s
Peak inverse grid 1 voltage	—	450	V
Loaded grid 1 bias voltage	—	—	see note 8
Peak grid 1 drive current	0.3	1.0	A

Cathode

Heater voltage	$6.3 \pm 5\%$	—	V
Tube heating time	5.0	—	min

Environmental

Ambient temperature	-50	+90	$^{\circ}$ C
Altitude	—	10 000	ft
	—	3	km

CHARACTERISTICS

	Min	Typical	Max	
Critical d.c. anode voltage for conduction (see note 9)	—	0.5	2.0	kV
Anode delay time (see notes 9 and 10)	—	0.15	0.25	μ s
Anode delay time drift (see notes 9, 11 and 12)	—	20	50	ns
Time jitter (see notes 9 and 12)	—	1.0	5.0	ns
Recovery time				see note 13 and curves
Heater current (at 6.3V)	18	22	25	A

RATINGS FOR SINGLE SHOT OR CROWBAR SERVICE (See note 7)

D.C. forward anode voltage	25	kV max
Peak anode current	15 000	A max
Product of peak current and pulse length	0.6	A.s max
Repetition frequency	1 pulse per 10s	max

NOTES

1. Clamping is only permissible by the base.
2. A large area anode connector EEV type MA360 is recommended.
3. The maximum permissible peak forward voltage for instantaneous starting is 20kV and there must be no overshoot.
4. The peak inverse voltage must not exceed 10kV for the first 25 microseconds after the anode pulse.
5. This rate of rise refers to that part of the leading edge of the pulse between 25% and 75% of the pulse amplitude.
6. Measured with respect to cathode. In certain cases the maximum drive pulse voltage may be exceeded without damage to the tube; a maximum value of 2.5kV is then recommended. When grid 1 is pulse driven, the last 0.25 μ s of the top of the grid 1 pulse must overlap the corresponding first 0.25 μ s of the top of the delayed grid 2 pulse.

7. When d.c. priming is used on grid 1, a negative bias of 100 to 200V must be applied to grid 2 to ensure anode voltage hold-off. D.C. priming is recommended for crowbar service.
8. D.C. negative bias voltages must not be applied to grid 1. When grid 1 is pulse driven, the potential of grid 1 may vary between -10 and $+5V$ with respect to cathode potential during the period between the completion of recovery and the commencement of the succeeding grid pulse.
9. Typical figures are obtained on test using conditions of minimum grid drive. Improved performance can be expected by increasing the grid drive.
10. The time interval between the instant at which the rising unloaded grid 2 pulse reaches 25% of its pulse amplitude and the instant when anode conduction takes place.
11. The drift in delay time over a period from 10 seconds to 10 minutes after reaching full voltage.
12. For equipment where jitter and anode delay time drift are not important, the tube may be triggered by applying a single pulse to grid 2 and connecting grid 1 to grid 2 via a $100pF$ capacitor shunted by a $10M\Omega$ resistor. These components are incorporated in adaptor assemblies MA92 and MA179 (see page 5).
13. The recovery characteristics are controlled on a sampling basis.

X-RAY WARNING

X-rays are emitted by the CX1140 from the region of the anode, but the radiation is usually reduced to a safe level by the steel panels of the equipment in which the tube operates.

ADAPTOR ASSEMBLIES

In addition to standard top cap connectors and base sockets, a number of adaptor assemblies are available from English Electric Valve Company Ltd. They assist in the replacement of other types of thyatron by CX1140, as indicated below.

MA91 For replacing GHT3/CV5721.

A five-contact socket fitted with flexible leads and terminal tags, and mounted on an insulating base plate. It provides a conversion from base to flange type mounting.

MA92 For replacing 1754/5948 (CV3518).

Similar to MA91 but incorporates an RC network and is designed for use with CX1140 where a single pulse drive and flying lead connections are required. Where CX1140 and MA92 replace 1754/5948 (CV3518), it should be noted that no lead is provided for a hydrogen reservoir connection as the CX1140 does not require a separate supply.

MA179 For replacing 1754/5948 and with tube clamping.

A five-contact socket with flexible leads and terminal tags, mounted on an insulating base plate; it is fitted with a base clamp. It incorporates an RC network and is designed for use with CX1140 where a single pulse drive and flying lead connections are required.

See page 6 for conversion of 5949/1907 or 5949A socket to use CX1140.

Further information is contained in the leaflet 'Accessories for Hydrogen Thyratrons'.

Conversion of 5949/1907 or 5949A socket to use CX1140/CV8563

1) View of 5949/1907 or 5949A socket from underneath

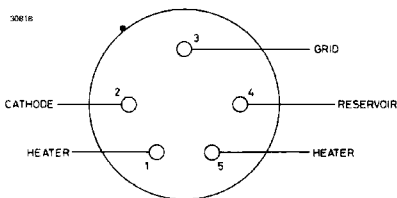

2) View of 5949/1907 or 5949A socket modified to use CX1140

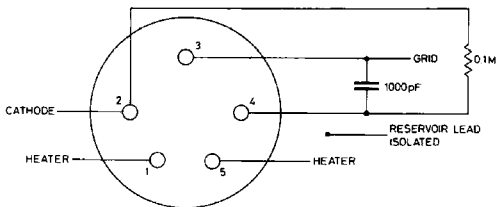

3) Conversion Procedure

The following components are required; they should be rated to withstand the existing grid drive power.

One 0.1M Ω resistor.

One 1000pF mica capacitor.

- Remove reservoir lead from pin 4 and isolate.
- Connect the 0.1M Ω resistor and 1000pF capacitor in parallel between pins 3 and 4.
- Plug in CX1140.

MAXIMUM RECOVERY CHARACTERISTICS

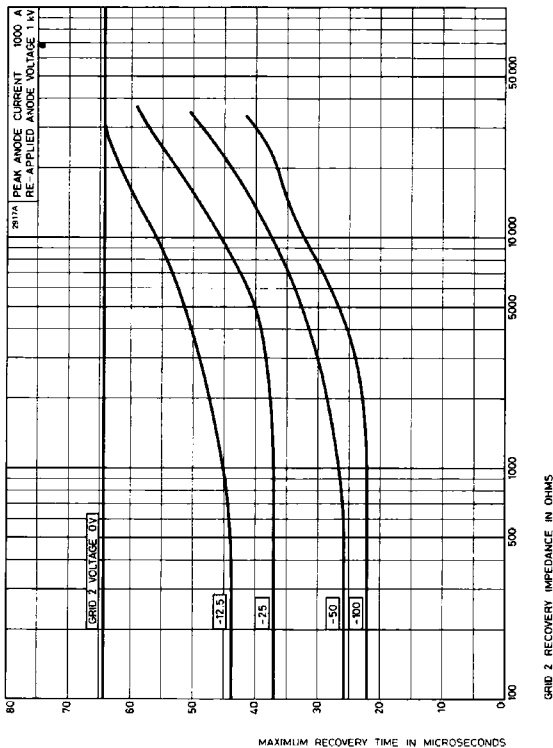

Whilst EEV has taken care to ensure the accuracy of the information contained herein it accepts no responsibility for the consequences of any use thereof and also reserves the right to change the specification of goods without notice. EEV accepts no liability beyond that set out in its standard conditions of sale in respect of infringement of third party patents arising from the use of tubes or other devices in accordance with information contained herein.

OUTLINE (All dimensions without limits are nominal)

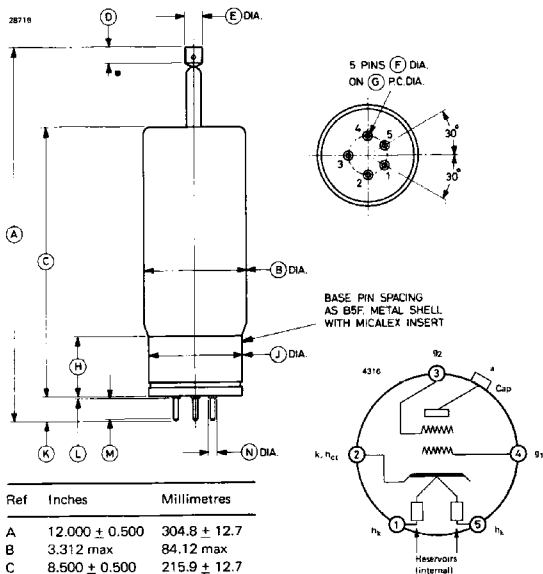

Ref	Inches	Millimetres
A	12.000 ± 0.500	304.8 ± 12.7
B	3.312 max	84.12 max
C	8.500 ± 0.500	215.9 ± 12.7
D	0.500 min	12.70 min
E	0.566 ± 0.007	14.38 ± 0.18
F	0.187 ± 0.003	4.750 ± 0.076
G	1.250	31.75
H	1.937	49.20
J	3.062 ± 0.062	77.77 ± 1.57
K	0.770 max	19.56 max
L	0.073 max	1.85 max
M	0.575 min	14.60 min
N	0.260 max	6.60 max

Millimetre dimensions have been derived from inches.

Pin	Element
1	Heater
2	Cathode, connected internally to heater mid-point
3	Grid 2
4	Grid 1
5	Heater
Top cap	Anode