

Photomultiplier Tube⁹

RUGGED VIBRATION-RESISTANT STRUCTURE

S-11 RESPONSE ELECTROSTATICALLY FOCUSED
10-STAGE, HEAD-ON, FLAT-FACEPLATE TYPE DYNODE STAGES

For Detection and Measurement of Nuclear Radiation and other Low-Level Light Sources. Especially Useful in Missile and Rocket Service and other Industrial and Military Applications where Severe Environmental Conditions may be Encountered.

General:

Spectral Response.	S-11
Wavelength of Maximum Response	4400 ± 500 angstroms
Cathode, Semitransparent	Cesium-Antimony
Minimum area	1.2 sq. in.
Minimum diameter	1.24"
Window	Lime Glass (Corning ^a No.0080), or equivalent
Shape.	Plano-plano
Index of refraction at 5893 angstroms.	1.51
Dynode Material.	Copper-Beryllium
Direct Interelectrode Capacitances (Approx.):	
Anode to dynode No.10	3.2 pf
Anode to all other electrodes.	5.0 pf
Maximum Overall Length (Excluding semiflexible leads).	3.18"
Maximum Diameter	1.56"
Operating Position	Any
Weight (Approx.)	2.2 oz
Bulb	T12
Magnetic Shield.	Millen Co. ^b , or equivalent
Base	Special
Terminal Diagram:	BOTTOM VIEW

Lead 1 & Metal Flange-	
Photocathode	
Lead 2 - Dynode No.1	
Lead 3 - Dynode No.3	
Lead 4 - Dynode No.5	
Lead 5 - Dynode No.7	
Lead 6 - Dynode No.9	
Lead 7 - Anode	
Lead 8 - Dynode No.10	
Lead 9 - Dynode No.8	
Lead 10 - Dynode No.6	
Lead 11 - Dynode No.4	
Lead 12 - Dynode No.2	

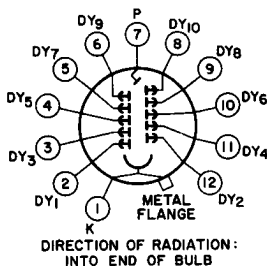

Maximum Ratings, Absolute-Maximum Values:

DC Supply Voltage:	
Between anode and cathode.	1500 volts
Between anode and dynode No.10	250 volts
Between consecutive dynodes.	200 volts
Between dynode No.1 and cathode.	400 volts
Average Anode Current ^c	1 ma
Average Cathode Current ^{c,d}	2 μ a
Ambient Temperature.	75 °C



Characteristics Range Values:

Under conditions with dc supply voltage (E) across a voltage divider providing 1/6 of E between cathode and dynode No. 1; 1/12 of E for each succeeding dynode stage; and 1/12 of E between anode and dynode No. 10 and anode.

With E = 1250 volts (Except as noted)

	Min.	Typ.	Max.	
Sensitivity:				
Radiant, at 4400 angstroms		8×10^{-3}	-	a/w
Cathode radiant, at 4400 angstroms	-	0.048	-	a/w
Luminous, at 0 cps ^e	3	10	90	a/lm
With dynode No. 10 as output electrode ^f	-	6	-	a/lm
Cathode luminous:				
With tungsten light source ^g	4×10^{-5}	6×10^{-5}	-	a/lm
With blue light source ^h	4×10^{-8}	6×10^{-8}	-	a
Current Amplification	-	1.7×10^{-5}	-	
Equivalent Anode-Dark-Current Input at a luminous sensitivity of 10 a/lm ^j				
	-	5×10^{-10}	2×10^{-9}	1m
Equivalent Noise Input ^{k, m}				
	-	2.8×10^{-12}	1.8×10^{-11}	1m
Anode-Pulse Rise Time ⁿ	-	2.4×10^{-9}	-	sec
Electron Transit Time ^p	-	2.9×10^{-8}	-	sec
Quantum Efficiency at 4300 angstroms	-	14	-	%

With E = 750 volts (Except as noted)

	Min.	Typ.	Max.	
Sensitivity:				
Radiant, at 4400 angstroms	-	1.8×10^{-2}	-	a/w
Cathode radiant, at 4400 angstroms	-	0.048	-	a/w
Luminous, at 0 cps ^e	-	0.22	-	a/lm
Cathode luminous:				
With tungsten light source ^g	4×10^{-5}	6×10^{-5}	-	a/lm
With blue light source ^h	4×10^{-8}	6×10^{-8}	-	a
Current Amplification	-	3.7×10^{-3}	-	
Equivalent Anode-Dark-Current Input at a luminous sensitivity of 10 a/lm ^j				
	-	5×10^{-10}	2×10^{-9}	1m
Anode-Pulse Rise Time ^k	-	3.1×10^{-9}	-	sec
Electron Transit Time ^p	-	3.8×10^{-8}	-	sec

^a Made by Corning Glass Works, Corning, New York.

^b Magnetic shielding in the form of foil or tape as available from the James Millen Manufacturing Company, 150 Exchange Street, Malden 48, Massachusetts, or equivalent.



- c Averaged over any interval of 30 seconds maximum.
- d For a uniformly illuminated area of 0.5 square inches minimum.
- e Under the following conditions: The light source is a tungsten-filament lamp having a lime-glass envelope. It is operated at a color temperature of 2870° K and at a light input of 10 microlumens.
- f An output current of opposite polarity to that obtained at the anode may be provided by using dynode No. 10 as the output electrode. With this arrangement, the load is connected in the dynode No. 10 circuit and the anode serves only as a collector. The curves under *Typical Anode Characteristics* do not apply when dynode No. 10 is used as the output electrode.
- g Under the following conditions: The light source is a tungsten-filament lamp having a lime-glass envelope. It is operated at a color temperature of 2870° K. The value of light flux is 0.01 lumen and 200 volts are applied between cathode and all other electrodes connected as anode.
- h Under the following conditions: Light incident on the cathode is transmitted through a blue filter (Corning C.S. No. 5-58, polished to 1/2 stock thickness—Manufactured by the Corning Glass Works, Corning, New York) from a tungsten-filament lamp operated at a color temperature of 2870° K. The value of light flux incident on the filter is 0.01 lumen and 200 volts are applied between cathode and all other electrodes connected as anode.
- j At a tube temperature of 25° C. Dark current may be reduced by use of a refrigerant.
- k For maximum signal-to-noise ratio, operation with a supply voltage (E) below 1250 volts is recommended.
- m Under the following conditions: Supply voltage (E) is as shown, 25° C tube temperature, external shield connected to cathode, bandwidth, 1 cycle per second, tungsten-light source at a color temperature of 2870° K interrupted at a low audio-frequency to produce incident radiation pulses alternating between zero and the value stated. The "on" period of the pulse is equal to the "off" period.
- n Measured between 10 per cent and 90 per cent of maximum anode-pulse height. This anode-pulse rise time is primarily a function of transit-time variations and is measured under conditions with an incident-light fully illuminating the photocathode.
- p The electron transit time is the time interval between the arrival of a delta function light pulse at the entrance window of the tube and the time at which the output pulse at the anode terminal reaches peak amplitude. The transit time is measured under conditions with the incident light fully illuminating the photocathode.
- q Alternate designation for Multiplier Phototube.

**SPECTRAL-SENSITIVITY CHARACTERISTIC
OF PHOTSENSITIVE DEVICE HAVING S-II RESPONSE
is shown at the front of this Section**

ENVIRONMENTAL TESTS:

The 4461 is designed to withstand the shock, vibration, and acceleration tests shown below which are equivalent to those specified in MIL-E-5272C* for equipment mounted on the structures of missiles propelled or launched by high-thrust rocket engines. The accelerations specified in these tests are applied directly to the tubes.

One-Hundred Per-Cent Shock and Vibration Testing:

Each 4461 is subjected in sequence to shock and then to vibration as specified below with the tube non-operating.

Shock. These tests are performed first, per method of MIL-E-5272C*, Paragraph 4.15-5.1, Procedure V, on apparatus which provides a half-wave sinusoidal shock pulse. One-hundred per-cent testing of all 4461's is performed. Each 4461 (non-operating) is subjected to three impact shocks in each direction of the three orthogonal axes. The peak acceler-



ation of the impact shock is 30 ± 3 g's and the time duration is 11 ± 1 milliseconds. Each tube is subjected to a total of 18 impact shocks.

Vibration. These tests are performed next, on apparatus which applies variable-sinusoidal frequency vibration to the tube, per method of MIL-E-5272C*, paragraph 4.7.14 and paragraph 4.7.14.1. One hundred per-cent testing of all 4461's is performed. Each 4461 is vibrated in each of the three orthogonal axes as specified in the schedule below. A vibration cycle has a duration of 5 minutes per axis in which time the frequency is varied logarithmically from 20 to 2000 and back to 20 cycles per second. One vibration cycle is performed for each axis and the total test period for each tube is 15 minutes.

Double Amplitude Inches	Acceleration g's	Frequency cps	Cycle Duration Per Axis minutes
0.050 ± 0.005	-	20 - 87	} 5
-	20 ± 2	87 - 2000	
-	20 ± 2	2000 - 87	
0.050 ± 0.005	-	87 - 20	

Tube Rejection Criterion. Upon completion of the *Shock and Vibration Testing* each tube is tested at a anode-to-cathode voltage of 1250 volts with the light level incident on the tube adjusted to provide an anode current of approximately 8 microamperes. Electrical and/or mechanical tube failures due to shock or vibration will be observed during the vibration test when the specified anode current is monitored. Tube rejection criterion for both tests is that the anode current of 8 microamperes will not change more than ± 20 per cent upon completion of the vibration test for each axis.

Design Tests:

Vibration. These tests are performed under conditions equivalent to those described in MIL-E-5272C*, paragraph 4.7.14 and paragraph 4.7.14.1. The vibration cycle has a duration of one hour and two cycles are performed for each of the three orthogonal axes. The total test period for each tube is six hours.

Acceleration. These tests are performed in a centrifuge providing unidirectional acceleration by a method equivalent to that specified in MIL-E-5272C*, paragraph 4.16.3, Procedure III, except that tubes are subjected for one minute to an increased acceleration test level of 100 ± 10 g's in both directions of the three orthogonal axes. The tubes are non-operating during the test.

* Military Specification MIL-E-5272C (ASG), 13 April 1959; and Amendment 1, 5 January 1960.

OPERATING CONSIDERATIONS

The *operating stability* of the 4461 is dependent on the magnitude of the anode current and its duration. When operating at high average values of anode current, a drop in sensitivity (sometimes called fatigue) may be expected. The extent of the drop below the tabulated sensitivity values depends on the severity of the operating conditions. After a period of idleness, the 4461 usually recovers a substantial percentage of such loss in sensitivity.

It is recommended that the average anode current be well below the maximum rated value of 1 milliamperere when stability of operation is important. When maximum stability is required, the average anode current should not exceed 10 microamperes.

Electrostatic and/or *magnetic shielding* of the 4461 may be necessary.

Adequate *shielding* should be provided to prevent extraneous radiation from reaching any part of the 4461.

The *high voltages* at which the 4461 is operated are very dangerous. Before any part of the circuit is touched, the power supply switch should be turned off and both terminals of any capacitors grounded.

Accompanying *Typical Voltage-Divider Arrangement* is recommended for use with the 4461. *Resistance values* for the voltage-divider arrangement range from 10,000 ohms per stage to 1,000,000 ohms per stage. The choice of resistance values for the voltage-divider network is usually a compromise. If low values of resistance per stage are utilized, the power drawn from the regulated power supply and the required wattage rating of the resistors increase. Phototube noise may also increase due to heating if the divider network is near the photocathode. The use of resistance values near 1 megohm per stage may cause deviation from linearity if the voltage-divider current is not maintained at a value several times that of the maximum value of anode current, and may limit anode-current response to pulsed light. The latter effect may be reduced by connecting capacitors between the leads for dynodes No. 7 and No. 8, dynodes No. 8 and No. 9, dynodes No. 9 and No. 10, and between dynode No. 10 and anode return. In addition to non-linearity and pulse-limiting effects, the use of resistance values exceeding 1 megohm per stage make the 4461 more susceptible to leakage effects between terminals with possible resulting deviation in interstage voltage leading to a loss of current amplification.



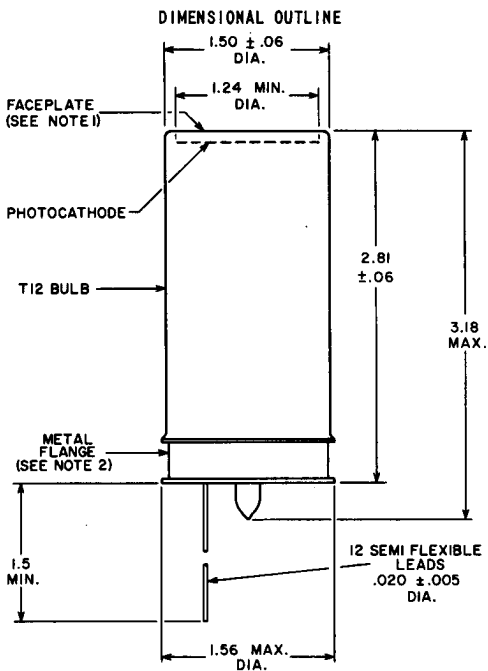

92CS-11464R2

DIMENSIONS IN INCHES

Center line of bulb will not deviate more than 2° in any direction from the perpendicular erected at the center of bottom of the base flange.

Note 1: Deviation from flatness within the 1.24 inch diameter area will not exceed 0.010 inch from peak to valley.

Note 2: The metal flange should never be employed for mechanical mounting purposes.



TYPICAL VOLTAGE-DIVIDER ARRANGEMENT

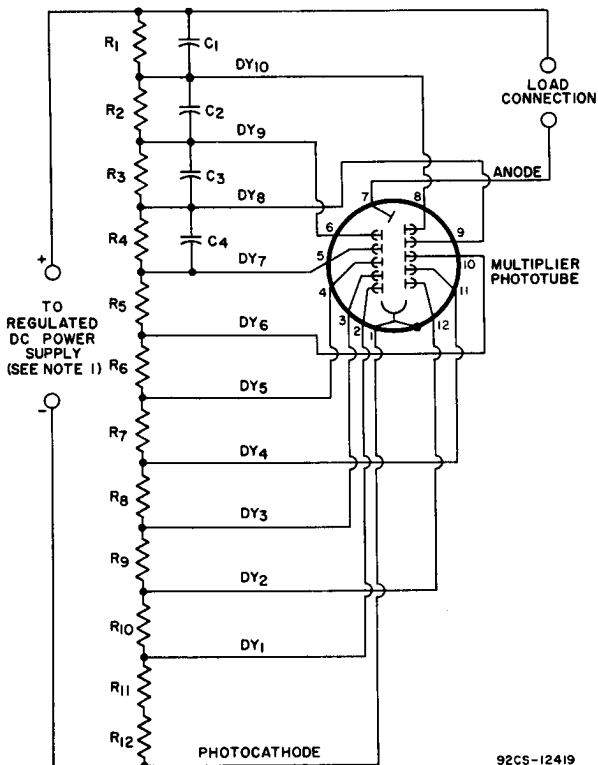

C_1 : 0.05 μ f, 500 volts (dc working)

C_2 : 0.02 μ f, 500 volts (dc working)

C_3 : 0.01 μ f, 500 volts (dc working)

C_4 : 0.005 μ f, 500 volts (dc working)

R_1 through R_{12} : 33,000 ohms, 2 watts

Note 1: Adjustable between approximately 500 and 1500 volts DC.

Note 2: Capacitors C_1 through C_4 should be connected at tube socket for optimum high-frequency performance.



Typical Anode Characteristics

DYNODE-NO.1-TO-CATHODE VOLTS = 208
 EACH SUCCEEDING STAGE VOLTS = 104
 LIGHT SOURCE IS A TUNGSTEN-FILAMENT LAMP
 OPERATED AT COLOR TEMPERATURE OF 2870° K.

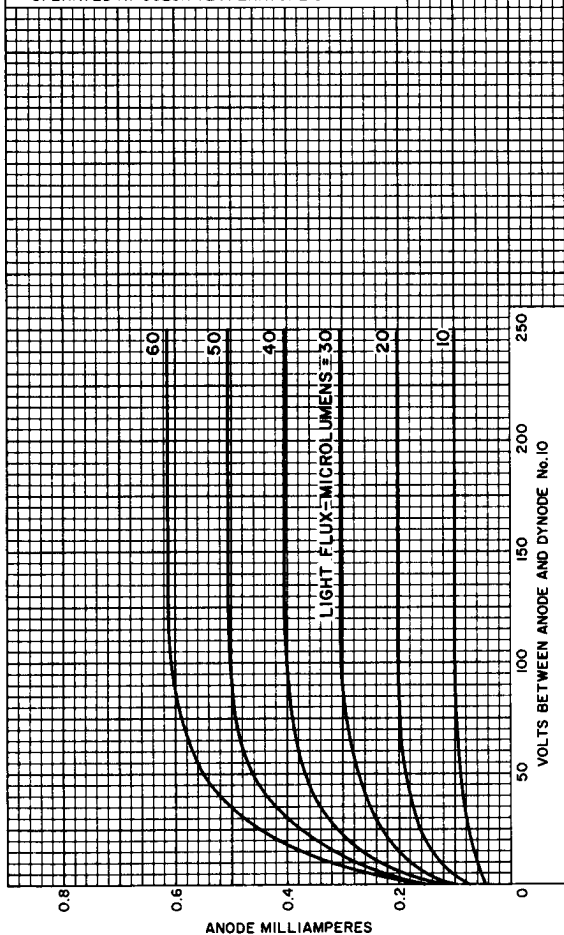

92CM-12414



Typical Sensitivity And Current Amplification Characteristics

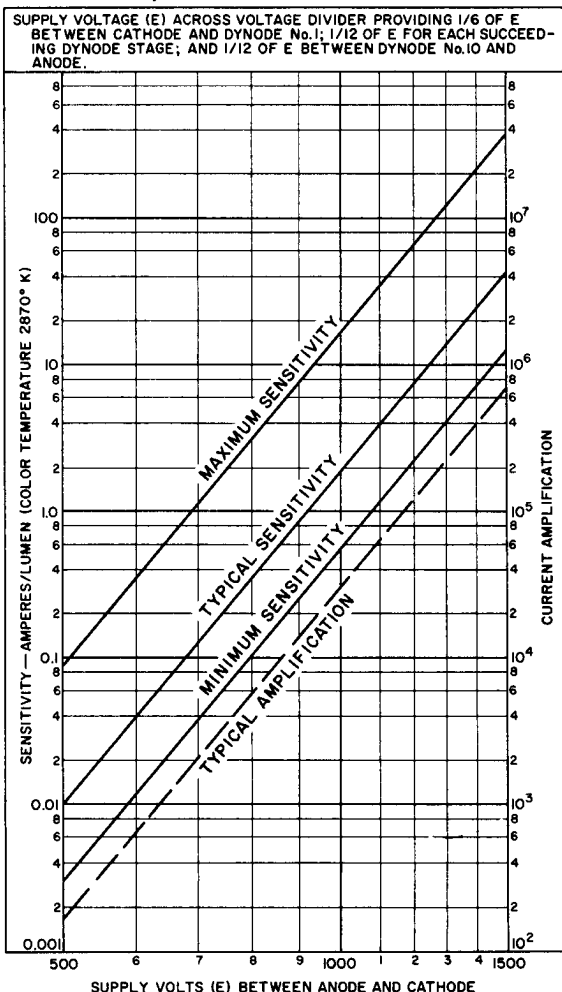

92CM-12412



Typical Anode-Dark-Current Characteristic

LUMINOUS SENSITIVITY IS VARIED BY ADJUSTING THE SUPPLY VOLTAGE (E) ACROSS VOLTAGE DIVIDER WHICH PROVIDES 1/6 OF E BETWEEN CATHODE AND DYNODE No.1; 1/12 OF E FOR EACH SUCCEEDING STAGE; AND 1/12 OF E BETWEEN DYNODE No.10 AND ANODE.

TUBE TEMPERATURE = 25° C

DASHED PORTION INDICATES INSTABILITY.

LIGHT SOURCE IS A TUNGSTEN-FILAMENT LAMP OPERATED AT A COLOR TEMPERATURE OF 2870° K.

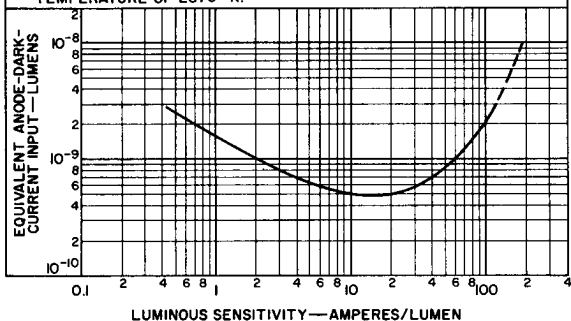

92CS-12410

Typical Time Resolution Characteristics

SUPPLY VOLTAGE (E) ACROSS VOLTAGE DIVIDER PROVIDING 1/6 OF E BETWEEN CATHODE AND DYNODE No.1; 1/12 OF E FOR EACH SUCCEEDING DYNODE STAGE; AND 1/12 OF E BETWEEN DYNODE No.10 AND ANODE. THE PHOTOCATHODE IS FULLY ILLUMINATED.

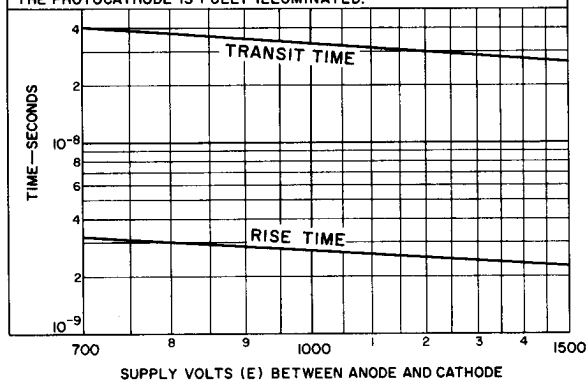

92CS-12408

