

PHILIPS

electronic measuring and microwave notes

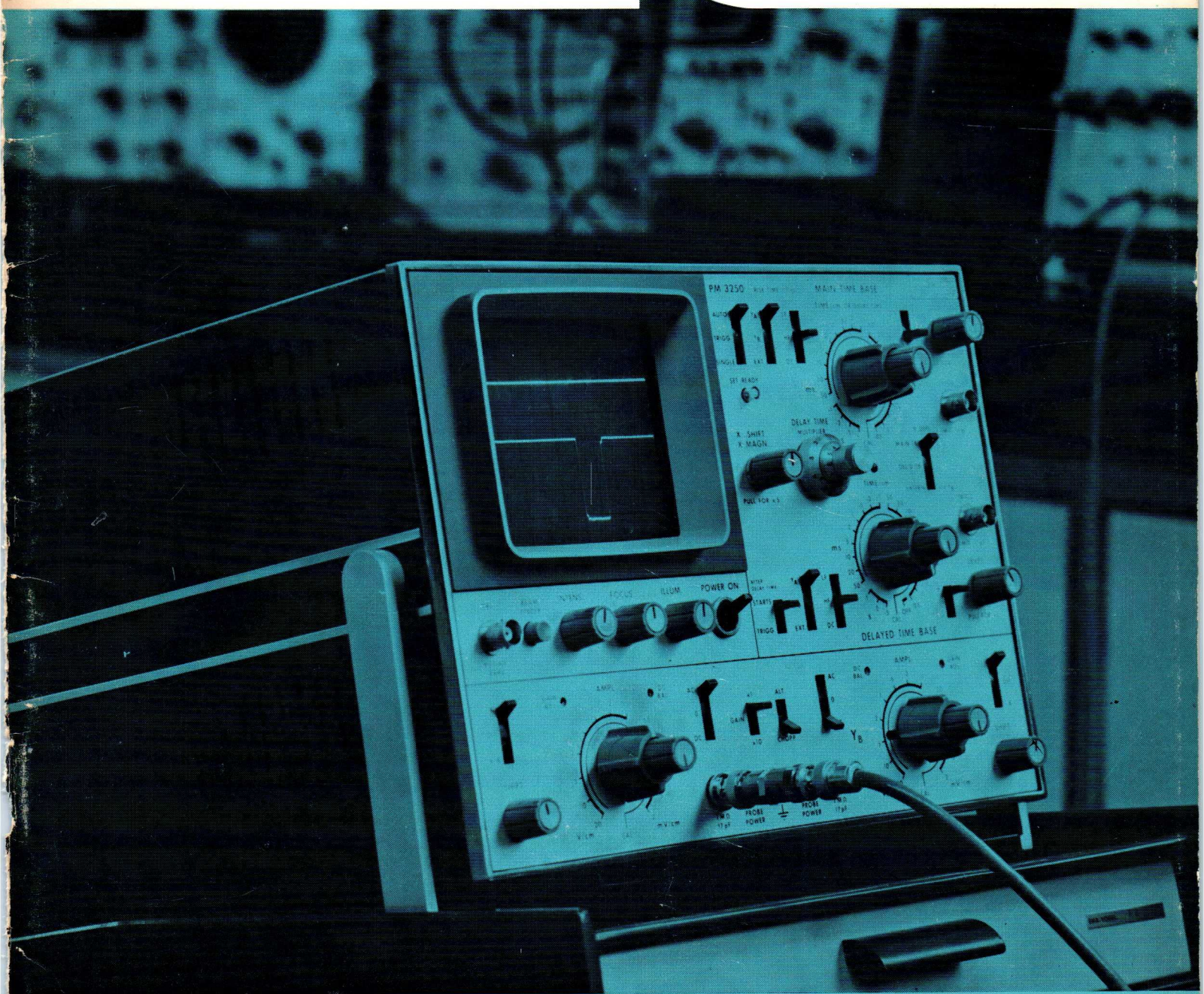

PHILIPS

electronic measuring and microwave notes

Introduction

The quarterly periodical Electronic Measuring and Microwave Notes, provides information about the application and design of Philips electronic measuring and microwave instruments and also surveys the new instruments which are regularly added to the Philips programme.

The information is intended to assist users in getting the maximum benefit out of instrument which they already possess and to help them in choosing new instruments which will best meet their particular measuring or microwave problems

In this issue

	page
Summary of the PM 3250 oscilloscope specifications	2
The dual-trace 50 MHz oscilloscope	4
Pre-amplifier	7
Drift correction	9
Trigger amplifier	11
Switching amplifier	12
Blocking oscillator and multivibrator	14
Delay line driver, delay line and terminating amplifier	15
Construction of delay line	16
Output amplifier	17
Functional description of the horizontal deflection system	18
The automatic free-run circuit	22
The integrator	23
The hold-off circuits	24
The horizontal amplifier	26
Z amplifier	27
Cathode-ray tube	29
Calibration generator	30
Mechanical construction	31
The PM 9350 probe	33
The measurement of relatively small signals with the aid of the PM 3250	34
The display of A-B and B or -B	36
Accurate time measurements with an oscilloscope	38

Published by

n.v. Philips' Gloeilampenfabrieken, Eindhoven, the Netherlands

Editor

T. Sudar, n.v. Philips' Gloeilampenfabrieken, Test and Measuring Instruments Department, Eindhoven.

Layout

Fr. B. van de Vegte, Waalre

The front cover

of this issue shows the PM 3250 dual-trace 50 MHz oscilloscope

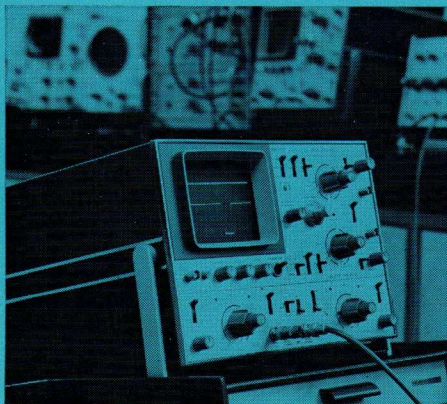

Introduction

Every new instrument introduced should make a tangible contribution to efficiency in this technological age. This ultimate goal of all development, production and marketing teams has certainly been reached with the PM 3250 double-trace oscilloscope, to which this issue of Electronic Measuring and Microwave Notes is devoted. The "extras" to be found in this instrument, such as the differential measuring circuit, the drift correction circuit, the large part of the front panel taken up by the CRT screen and the high sensitivity — make the PM 3250 a high-class tool with a wide range of applications. The simplified operation (resulting from a human-engineering approach), the good serviceability and the well chosen accessories reflect the awareness of the team that modern instrumentation requires more than just a single piece of equipment — a whole spectrum of measuring capability has to be provided. Our readers will be well aware that modern instrument design is such a complex business that individual activity — no matter how talented — must give way to teamwork here. In order to drive this point home a little further, we give on the next page a photo of the PM 3250 surrounded by the development team, the interplay of whose varied skills gave built to this versatile instrument. We hope that the detailed information given in this issue will bring our readers round to our point of view — that the PM 3250 is an oscilloscope after the heart of every discriminating user.



The PM 3250 with the team engaged in the development

please fold-out ►

Summary of the PM 3250 oscilloscope specifications

Y-Axis

2 identical amplifiers (channel A and B).

Modes of operation:

Channel A only

± channel B only

A and ± B chopped at 600 kHz

A and ± B alternate

(A—B) only

(A—B) and ± B chopped*

(A—B) and ± B alternate*

* in these positions both (A—B) and B are displayed, so it is possible to display simultaneously the differential signal (A—B) and the signal on channel B

Amplifiers:

Drift compensated, DC coupled type amplifiers

Bandwidth:

DC : 0 to 50 MHz

AC : 3 Hz to 50 Mz

Rise time:

7 ns

Deflection coefficient:

13 calibrated positions from 2 mV/div to 20 V/div

Tolerance ± 3%

Continuous control: 1:2.5 (not calibrated)

Magnification:

x10 magnification of gain (result 200 μV/div at reduced bandwidth of 0—5 MHz)

Overshoot:

Less than 2 % at maximum sensitivity

Input:

Asymmetrical, choice of AC/O/DC. In position O the amplifier is decoupled from the input and connected to earth

Connectors BNC

Input impedance 1 MΩ//20 pF

Maximum input voltage: 400 V (DC + AC peak)

Input RC time 50 ms

Positioning range:

3 x useful screen height (24 divisions)

At x 10 gain it increases to 160 divisions

Visible signal delay:

20 ns, total line delay 65 ns

Calibration

Calibration voltage 600 mV ± 1 %

Frequency 2 kHz ± 1 %

Calibration current 6 mA (short circuit),

tolerance ± 2 %

Beam finder

The deflection sensitivity can be reduced by means of a push button switch

X-Axis

One DC coupled amplifier

Deflection by:

Main time base

Delayed time base

External voltage via channel Y_B, with a bandwidth of 0 to 5 MHz and maximum sensitivity 2mV/div

Main time base

Sweep speeds:

1 s/div up to 50 ns/div in 23 calibration steps

Tolerance ± 3 %.

Continuous control 2:2.5 (not calibrated).

Magnification:

5x (so max. sweep speed is 10 ns/div)

Tolerance ± 5 %

Positioning range:

With x5 magnification the complete trace can be brought on the screen

Mode:

Auto, Triggered, Single shot

Triggering:

Source: Internal channel A

Internal channel B or external

Slope: "+" or "-"

Coupling: LF: 3 Hz to 1 MHz

HF: 2 kHz to 50 MHz

DC: 0 to 50 MHz

Minimum trigger signal up to 50 MHz:

Internal 1 div

External 1 V

External input: BNC connector

Input impedance: 1 MΩ//20 pF (same as for vertical inputs)

Maximum input voltage: 300 V (DC+AC peak)

Level:

Potentiometer control. x5 range increase with the aid of a pull switch

Internal: in position x5 continuously adjustable

over 40 divisions: in position x1 continuously

adjustable over 8 divisions

External: in position x5 continuously adjustable

over 35 V; in position x1 continuously adjustable

over 7V

Time base signal output:

BNC connector on rear side

Open circuit 0—8 V

Short circuit 0—1.7 mA

Delayed time base

Sweep speeds:

0.5 s/div up to 50 ns/div (22 calibrated steps)

Tolerance: ± 3 %

Continuous control 1 : 2.5 (not calibrated)

In position "off" the time base is switched off

Magnification:

5x (so max. sweep speed is 10 ns/div)

Tolerance: ± 5 %

Mode:

Triggered immediately after delay interval by main sweep

Triggered after delay interval by measuring signal

(for jitter-free measurements)

Triggering:

See main time base

Delayed gate output:

BNC connector on rear side

Open circuit 0—2 V

Short circuit 0—3 mA

CRT

Type:

D14—160 GH/09 with internal graticule

Useful screen area 8 x 10 cm

Phosphor GH (P 31)

Total acc. voltage 10 kV

Continuous control of graticule illumination

Z modulation

Source:

Internal. External

Internal:

Brightness control by main time base

Brightness control by main time base intensified

by the delayed time base

Brightness control by delayed time base

in position "shopped" suppression of the beam

during switching

External:

DC coupled

Required voltage 1 V (for visible marking)

Input impedance: 1 MΩ//20 pF

Bandwidth DC . . . 5 MHz

AC coupled

Required voltage 1 V (for visible marking)

Input impedance: 50Ω

Bandwidth 3 kHz up to 50 MHz

Supply voltage

By means of voltage selector adjustable to mains voltages of 110 — 125 — 145 — 220 — 245 V

Voltage variations:

± 10 % variations can be tolerated with

negligible effect

Temperature range

Operating within specification: 0 to + 45°C

Operating: — 10 to + 55°C

Storage: — 40 to + 70°C

These temperature ranges are in conformity with IEC standard 68

Dimensions overall and weight

Height: 24.4 cm (9.61")

Width: 34.06 cm (13.41")

Depth: 53.4 cm (21.02")

Weight: 18.8 kg (41.4 lbs)

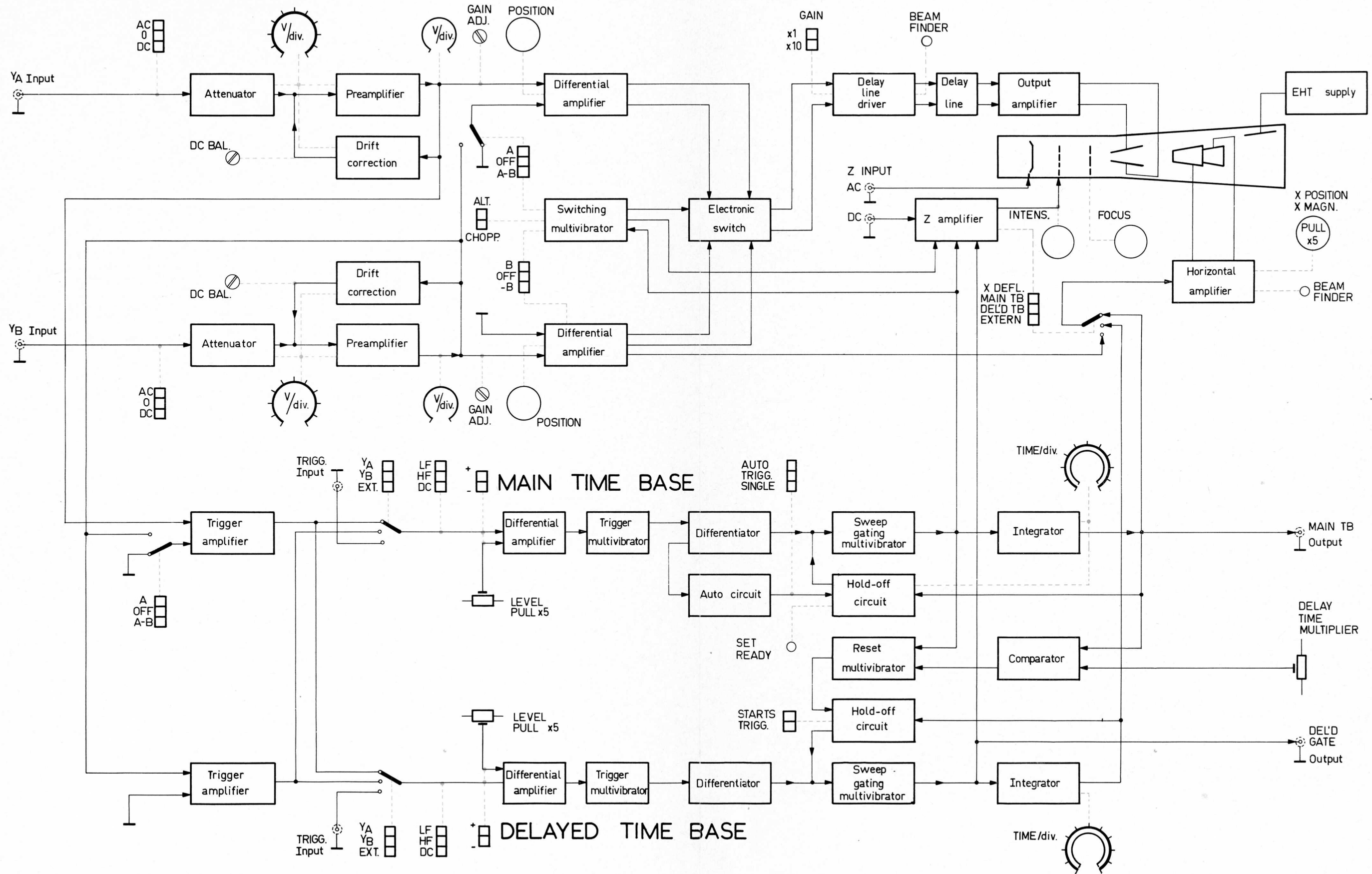

2. Block diagram of the oscilloscope PM 3250

The dual-trace 50-MHz oscilloscope

by J. J. Talens

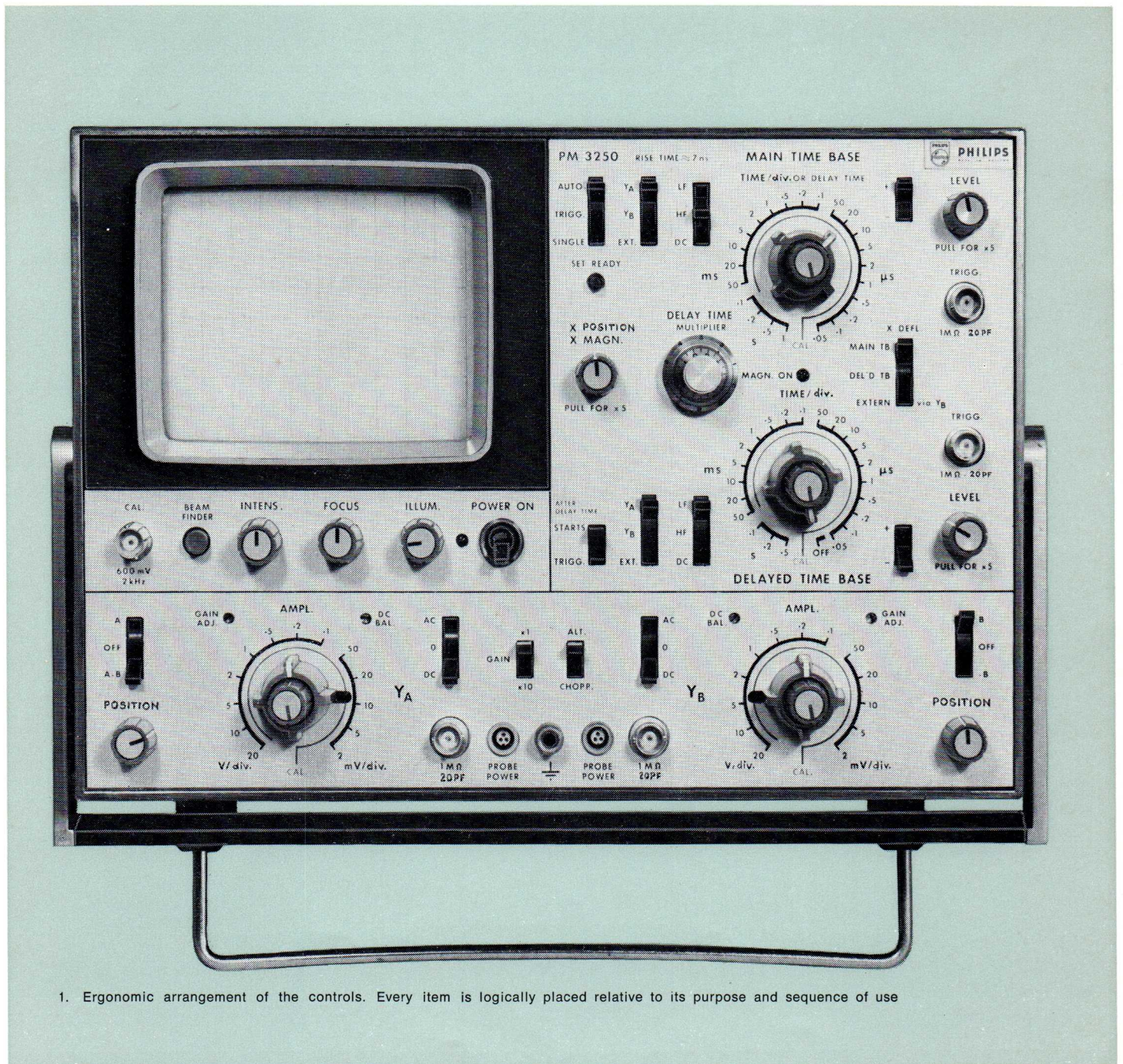

1. Ergonomic arrangement of the controls. Every item is logically placed relative to its purpose and sequence of use

General description

The Philips PM 3250 cathode-ray oscilloscope is a dual-trace instrument with a delayed time base. The bandwidth is 50 MHz. It has a very wide range of applications, in particular thanks to the extended range of the two vertical channels. The sensitivity at full bandwidth is 2 mV/div; the sensitivity can be increased by a factor of 10 by means of a switch. Both vertical channels can then be used up to 5 MHz with a sensitivity of 200 μ V/div. Like many modern Philips oscilloscopes, this instrument incorporates a drift-correction circuit. A MOST (metal-oxide-semiconductor transistor) chopper ensures very stable operation, even at this extreme sensitivity.

When the vertical gain selector is set to "x10", the vertical positioning range is also magnified by the same factor. This makes it possible to observe small signals superimposed on large ones, as if through a magnifying glass. The enormous scanning range (160 div) of the amplifiers also helps to make this possible.

Small difference voltages from two signals can also be made visible with the channel-selector switch in its differential position. An extra feature with this oscilloscope is that when it is used in its differential setting, the difference between the two signals in question can be displayed together with one of the original signals. In XY measurements, the Y_B channel is used for the horizontal deflection. Here again, the oscilloscope can be used in its differential setting, which makes it possible to display the difference between two signals (vertically) as a function of one of the signals (horizontally); for applications, see page 36.

Operation

As may be seen from the photo (see fig. 1) the control panel of the PM 3250 has been designed for ease of operation. The controls are functionally arranged in groups, while controls with a corresponding function are placed in the same relative position in each group.

It will be noticed that the vertical channel does not have the channel-selector switch (A, B, ALTERNATE, CHOPPED, ADDED) which is normal in dual-trace oscilloscopes. This switch has been replaced by an on-off switch for each channel, and a third switch (centrally placed because it affects both channels) which gives the choice between alternate and chopped.

This manner of switching, also in the circuits, which differs from that so far normal in dual-trace oscilloscopes, offers the user of the PM 3250 the unique possibility of displaying the signals (A—B) and B (or —B) simultaneously (CHOPP. or ALT.)

A lot of trouble has been taken to make the delayed time base as easy to operate

as possible. On the basis of ergonomic considerations, a two-knob system has been chosen; this makes it possible to read the setting with very little risk of error.

The system is designed so that the user no longer has any intractable switching problems when changing from the main time base to the delayed time base.

The tumbler switches on the control panel have been designed so that when they are all in their uppermost position, an image will generally be produced on the screen.

Block diagram

(see fold-out page fig. 2)

VERTICAL

The signals for the two vertical channels are fed in via a BNC input connector, and pass via the "AC-O-DC" switch to the input attenuator. When this switch is in its "O" position, the signal is cut off and the attenuator input is earthed. The input attenuator is followed by the pre-amplifier, which is provided with drift correction. After the pre-amplifier, the signal level is so high that drift has hardly any effect any more. After the pre-amplifier, the two vertical channels are different.

The Y_A signal is applied to one of the inputs of a differential amplifier. The other input can be either earthed or connected to the output of pre-amplifier Y_B with the aid of a selector switch (A, OFF, A—B). After this differential amplifier, the signal passes to the electronic switch.

The Y_B signal is fed to the input of a second differential amplifier, where the polarity of the signal can be reversed (180° phase shift) with the aid of a selector switch (B, OFF, —B). This signal is then also passed to the electronic switch. For XY measurements, the signal for the horizontal deflection is taken from channel B (after the differential amplifier).

The electronic switch is controlled by the switching multivibrator, which switches with a fixed frequency in position CHOPP. and in position ALT. is driven by the sweep gating multivibrator of the main time base. This switching multivibrator is brought to the appropriate fixed position when only one channel is in use, with the aid of the channel-selector switches and the X DEF. switch (in the position EXTERN via Y_B).

After the electronic switch, the signal arrives at the input of the delay line driver; the x1—x10 GAIN switch is included in this amplifier. This switch thus serves both channels at the same time; the positioning range is also affected by the GAIN switch since the POSITION controls (one for each channel) are included in the circuit before this point. The BEAM FINDER push button is also included in this section; this switch can be used to bring the image within the range of the graticule, no matter what the magnitude of the input signal.

The delay line, with a delay time of 65 nsec, is printed on epoxy-glass fibre, and sealed in plastic.

The signal finally reaches the vertical deflection system of the CRT via the output amplifier, a class-AB single-ended push-pull amplifier with complementary transistors.

The signals for the internal triggering of both time bases are taken from channels Y_A and Y_B after the pre-amplifier.

MAIN TIME BASE

After trigger amplifier A and trigger amplifier B, the trigger signals for the two time bases arrive at the source switch; it is also possible to trigger on external signals via a BNC connector on the front panel, when the source switch is set to EXT.

It may be mentioned here that trigger amplifier A also has a differential input, which is used in position "A—B" to trigger on the difference signal.

After the source switch come the coupling and slope switches. A differential amplifier in which the trigger signal is compared with a continuously variable DC voltage (LEVEL) feeds a signal to the trigger multivibrator, which in its turn delivers a signal of standard form, independent of the form of the input trigger signal. This LEVEL knob can be pulled out to give x5 range magnification, so that triggering can be carried out at any desired level, even with very large external trigger signals.

The standardized signals from the trigger multivibrator are fed to the input of the sweep gating multivibrator, via a differentiator which in its turn starts and stops the integrator (the saw-tooth generator proper). Various other control signals are also fed to the input of the sweep gating multivibrator, of which the main one is the voltage level delivered by the hold-off circuit; this signal determines whether the sweep gating multivibrator may react to new trigger pulses, to cause the integrator to produce a new saw-tooth. This may not happen until the previous saw-tooth has been completed, nor if the mode switch (which selects the mode of triggering) is at SINGLE and the SET READY button has not yet been depressed.

The sweep gating multivibrator can also receive a control signal from the automatic free-run circuit, which operates when the mode switch is set to AUTO (this switch also has a third position, TRIGG). The free-run circuit works as follows: when trigger pulses are received, operation is normal, as described above, but if these pulses are not received for 0.5 sec, the free-run circuit reacts to produce a voltage at the input of the sweep gating multivibrator, after which the time base is free-running.

If a trigger pulse is now received again, the voltage from the free-run circuit is no longer operative, and the time base is again triggered by the trigger pulse.

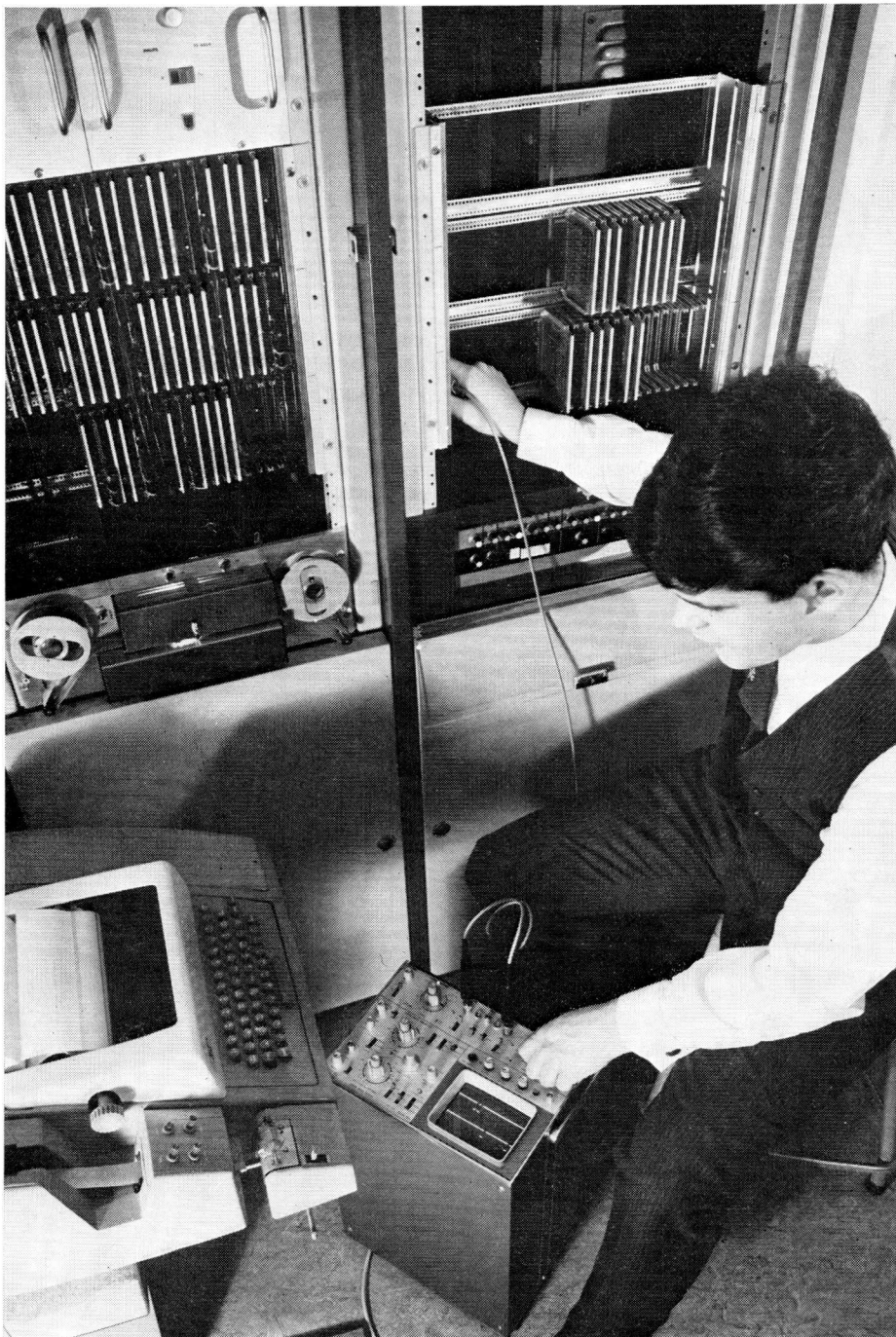

DELAYED TIME BASE

When the selector switch marked "AFTER DELAY TIME:" is in its STARTS position, the delayed time base starts at the moment when the instantaneous value of the output voltage of the main time-base generator is equal to a DC voltage whose level can be regulated by the DELAY TIME MULTIPLIER.

When the "AFTER DELAY TIME:" switch is set to TRIGG., the delayed time base starts when the first trigger pulse arrives at the input of the sweep gating multi-vibrator after the end of the pre-set delay time. This is known as the "jitter-free" position. The trigger channel of the delayed time base is identical with that of the main time base.

Horizontal amplifier

The input of the horizontal amplifier is connected, via the X DEFL. selector switch, with the integrator output of the main time base, the integrator output of the delayed time base or the output of the differential amplifier in the Y_B channel. The BEAM FINDER switch also forms part of the horizontal amplifier.

Z amplifier

The Z amplifier can be controlled by internal signals from the main time base, the delayed time base and the switching multi-vibrator in the position CHOPP; also external control signals (fed to an input at the back of the instrument) can be passed to the control grid (Wehnelt cylinder) of the CRT.

Pre-amplifier

by P. M. v. Cuijk

age, and is practically eliminated by the drift system, see page 9.

In position "O", the amplifier is disconnected from the BNC connector, and is earthed; capacitors C_1 and C_2 are short-circuited. In position "DC", the input is connected directly to the amplifier (via the attenuator I), and capacitors C_1 and C_2 remain short-circuited. Apart from the coupling this short-circuiting of C_1 is also necessary so that it can be discharged if required, C_1 can be charged while the switch is at AC, and but for this short-circuiting this charge could be retained for a long time, and could damage the circuit under investigation when the amplifier is switched back to AC. The discharge passes via R_3 , to cut down sparking in the switch.

The AC-O-DC switch is followed by the

a disadvantage is that attenuator III is needed in connection with the control system used. Since the amplification decreases, the attenuation must also decrease if distortion is to be avoided (see page 9)

In the other positions, from 50 mV/div the attenuation is provided by a high-ohmic attenuator in front of the amplifier.

The pre-amplifier proper now follows. This has a differential input, one input being connected to the attenuator and the other to the output of the control amplifier. The first receives the signal under investigation, and the other the correction signal. The first stage consists of two field-effect transistors TS_1 and TS_2 connected as source-followers. These ensure a high input impedance. The Zener diode D_2 in series with the source of TS_2 serves to

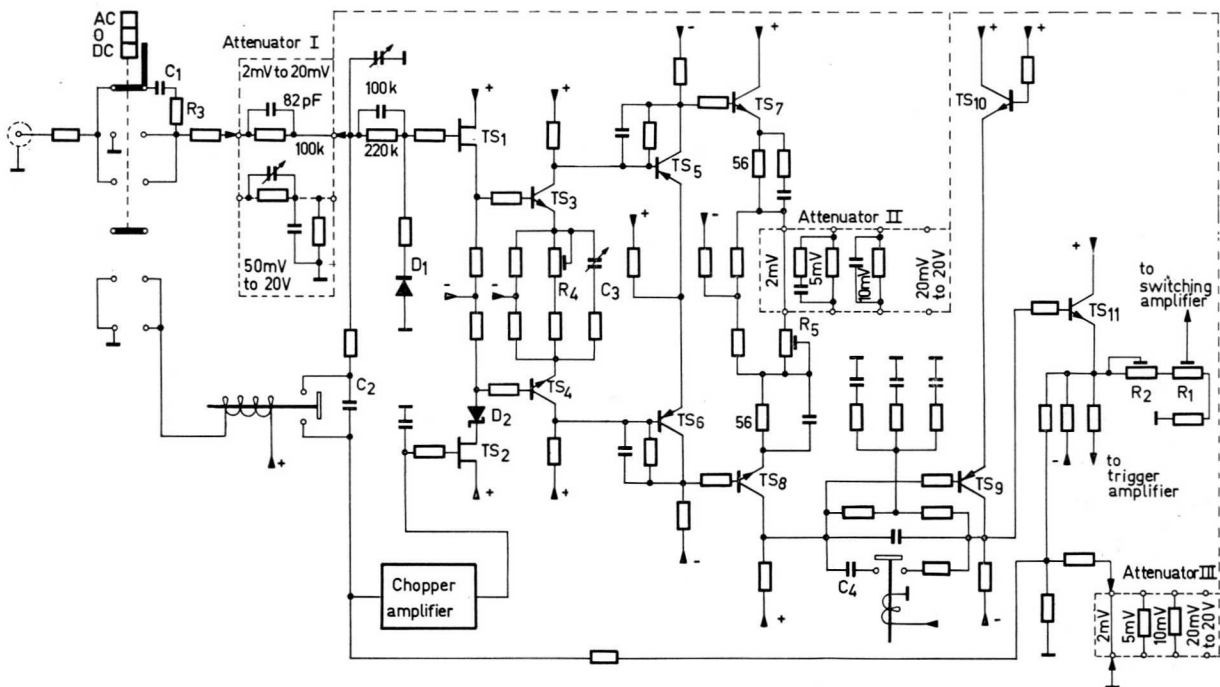

3. The circuit diagram of the pre-amplifier

The circuit diagram of the complete pre-amplifier for the Y_A channel is shown in fig. 3. The arrangement of the circuit for the Y_B channel is exactly identical, so this will not be described separately. This amplifier is stabilized by a control amplifier, is completely transistorized and has an input impedance of $1 M\Omega$ with an input capacitance of ≤ 20 pF.

Entering the circuit at the BNC connector, we arrive first at the AC-O-DC switch. When this switch is at "AC", the capacitors C_1 and C_2 are included in the circuit. Capacitor C_2 is included in order to stop any DC voltage from being applied directly to the input of the control amplifier owing to leakage C_1 . This DC voltage then enters the pre-amplifier as an interference volt-

attenuator, which as may be seen from the figure consists of three parts, I, II and III. This attenuator has 13 positions, namely: 2, 5, 10, 20, and 50 mV;

.1, .2, .5, 1, 2, 5, 10 and 20 V.

In the first four positions, attenuator I is not used as an attenuator. Here, a filter consisting of a 100 kohm resistor in parallel with an 82 pF capacitor is connected in series with the input. This filter, in combination with the filter consisting of a 220 kohm resistor in parallel with a 100 k capacitor and a diode D_1 , protects the input against overloading. The attenuation in these four positions is obtained by reducing the amplification of the amplifier. This has the advantage that the noise is also reduced at the same time. However,

match the output level of the control amplifier to the input of the amplifier proper. The next amplifier stage consists of two parts: TS_3 and TS_4 with current feedback and TS_5 and TS_6 with voltage feedback. The amplification of this stage is principally determined by the ratio of the voltage-feedback resistance to the current-feedback resistance. The current-feedback resistance consists partly of the potentiometer R_4 , so that the amplification can be adjusted. The trimmer capacitor C_3 can be used to get the most out of the high frequencies.

The second stage resembles the first, except that one side of the voltage-feedback part is omitted. The control system only compensates for the negative output drift.

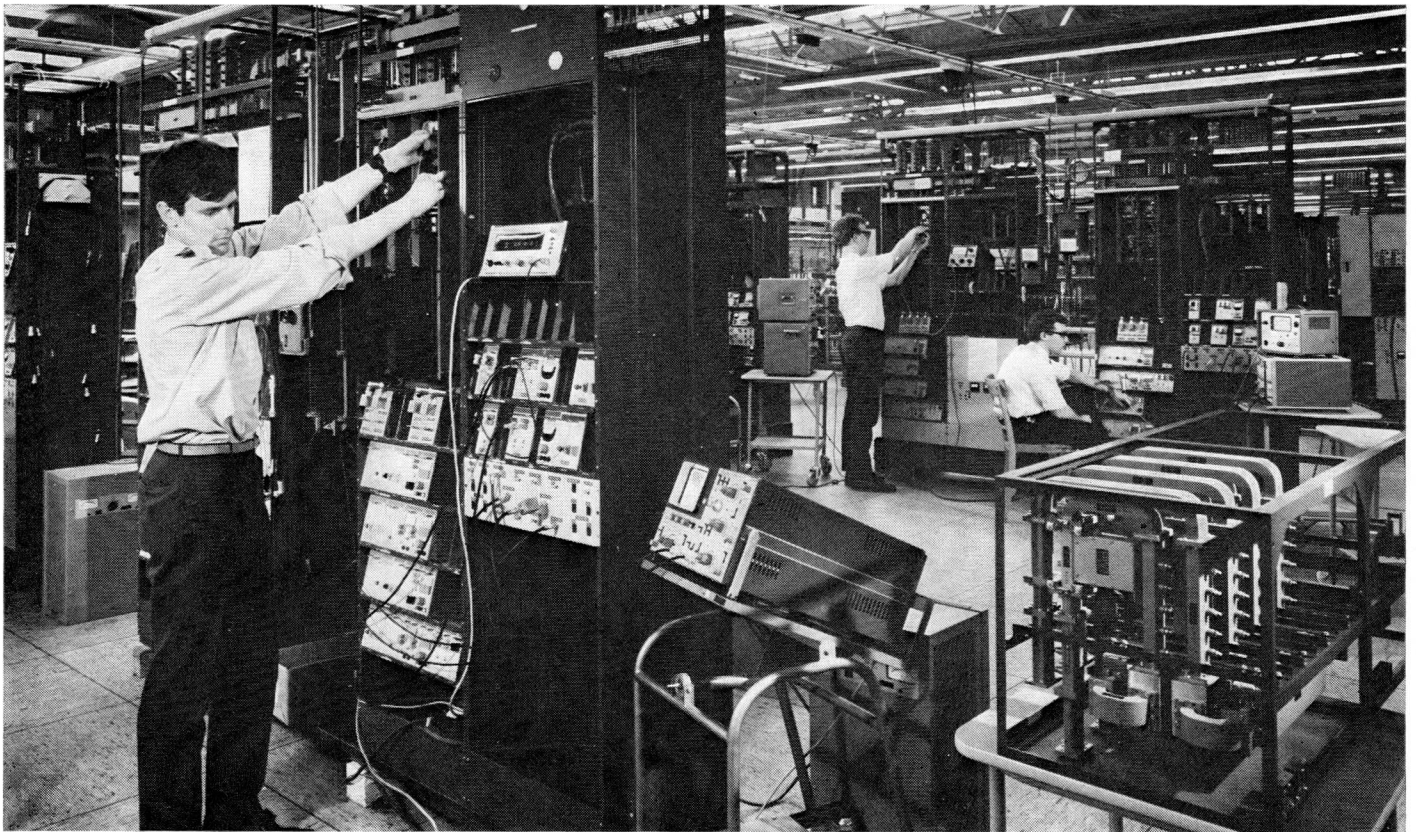

Attenuator II (already mentioned above) is connected between the emitters of TS_7 and TS_8 . In the most sensitive setting, the current-feedback resistance is again partly made up of a potentiometer R_5 so that the amplification can be varied. Since the amplifier must amplify as much as attenuator III attenuates, the system can be trimmed in the 20 mV and 2 mV positions, while the intermediate positions are provided with metal-film resistors with an accuracy of 0.25%.

The R and C in serie shunted across the 56-ohm emitter resistance of TS_7 , and the C in parallel with the 56-ohm emitter resistance of TS_8 , serve to get the most out of the highest frequencies in the 2 mV setting. In the 5 mV setting, this is done with an R and C in serie shunted across

the attenuator resistor in question, and in the 10 mV setting by a C in parallel with a resistor.

The transistor TS_{10} ensures that TS_9 has a low emitter impedance. The shunt feedback resistance of TS_9 is in two parts, with three RC combinations connected between the midpoint of these resistors and earth, to compensate for temperature effects occurring in the amplifier. Capacitor C_4 can also be shunted across this feedback resistance by means of a reed relay, to reduce the noise when the amplification elsewhere in the vertical channel is increased by a factor of 10. This reduces the bandwidth to 5 MHz.

This stage is followed by an emitter-follower (TS_{11}) to give an extra low output resistance. Attenuator III and a voltage

divider consisting of two potentiometers and a resistor are connected in the emitter lead of TS_{11} . The first potentiometer R_2 provides gain control, and is accessible on the front panel for screwdriver adjustment. (GAIN ADJ.) The signal is taken from the sliding contact of the second potentiometer R_1 .

The latter serves as continuous attenuation control and can be operated together with the attenuator step selector by means of a double knob. The signal for the trigger amplifier is also taken from the emitter of TS_{11} . With the gain adjustment R_2 in its middle position and with the continuous control in position "CAL", the output sensitivity is 60 mV/div in setting x1, and 6 mV/div in setting x10.

Drift correction

by J. A. Arts

$$V_2 = -B(V_1 + V_{d2}) \quad (2)$$

$$V_0 = A(V_2 - V_i - V_{d1}) \quad (3)$$

It follows from (1) and (3) that:

$$V_1 = \frac{V_2 - V_{d1}}{2}$$

(2) now becomes:

$$V_2 = -B \left(\frac{V_2 - V_{d1}}{2} + V_{d2} \right)$$

$$\text{or } V_2 \left(1 + \frac{B}{2} \right) = \frac{B}{2} V_{d1} - B V_{d2}$$

$$\text{or: } V_2 = \frac{B V_{d1}}{2 + B} - \frac{B V_{d2}}{1 + \frac{B}{2}}$$

From (3) follows:

$$\frac{V_0}{A} = \left(\frac{B}{2 + B} - 1 \right) V_{d1} - \frac{B V_{d2}}{1 + \frac{B}{2}} - V_i$$

or:

$$-\frac{V_0}{A} = V_i + \frac{2}{2 + B} V_{d1} + \frac{B}{1 + \frac{B}{2}} V_{d2}$$

or:

$$-\frac{V_0}{A} = V_i + \frac{1}{1 + \frac{B}{2}} V_{d1} + \frac{2}{1 + \frac{2}{B}} V_{d2}$$

The last two terms are drift voltages, which are equivalent to a drift voltage

$$V_{d1} = \frac{1}{1 + \frac{B}{2}} V_{d1} + \frac{2}{1 + \frac{2}{B}} V_{d2}$$

at the input.

We see that the drift of the pre-amplifier is reduced by a factor $(1 + B/2)$; with $B = 4000$ as in the PM 3250, this is thus a factor 2000. However, we now have an extra drift due to the control amplifier,

$$\text{given by } \frac{2}{1 + \frac{2}{B}} V_{d2} \approx 2 V_{d2}.$$

An indirect DC amplifier is used to keep this drift voltage as low as possible, since the drift of such an amplifier is determined only by the chopper, see fig. 5.

This chopper consists of two depletion-type MOSFET's (TS_1, TS_2), which are made conducting in turn. The resistance of a MOST in the conducting state is less than 150 ohm, while in the cut-off state it exceeds 10 Gohm, so that we may state with negligible error that the common point A is switched to and fro between the input voltage (fig. 6a) and earth (fig. 6b). The switching signal applied to the gates will pass via parasitic capacitances to point A and the input of the control amplifier. This switching signal thus makes its presence felt right at the input of the pre-amplifier, and is compensated by means of a square-wave voltage of opposite

The drift occurring in the vertical amplifier is corrected with the aid of an indirect DC amplifier, consisting of a chopper which converts the DC voltage applied to its input into a square-wave voltage, an AC amplifier and finally a demodulator which turns the amplified AC voltage back into DC.

We shall now calculate the effect of the above-mentioned amplifier (which we shall simply call the control amplifier from now on) with reference to fig. 4. We regard the drift voltages from the vertical and control amplifiers as being due to DC voltage sources at the input (V_{d1} and V_{d2}). We then find:

$$V_1 = \frac{V_i + \frac{V_0}{A}}{2} \quad (1)$$

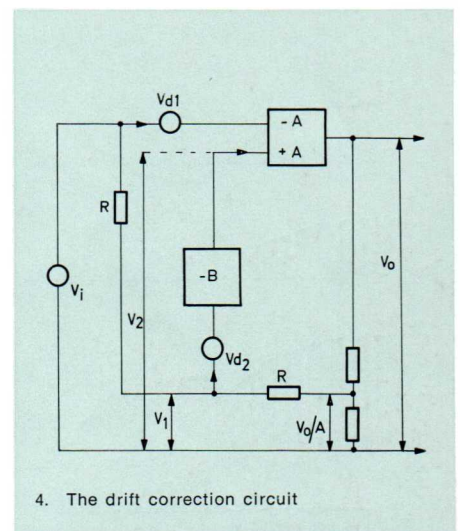

4. The drift correction circuit

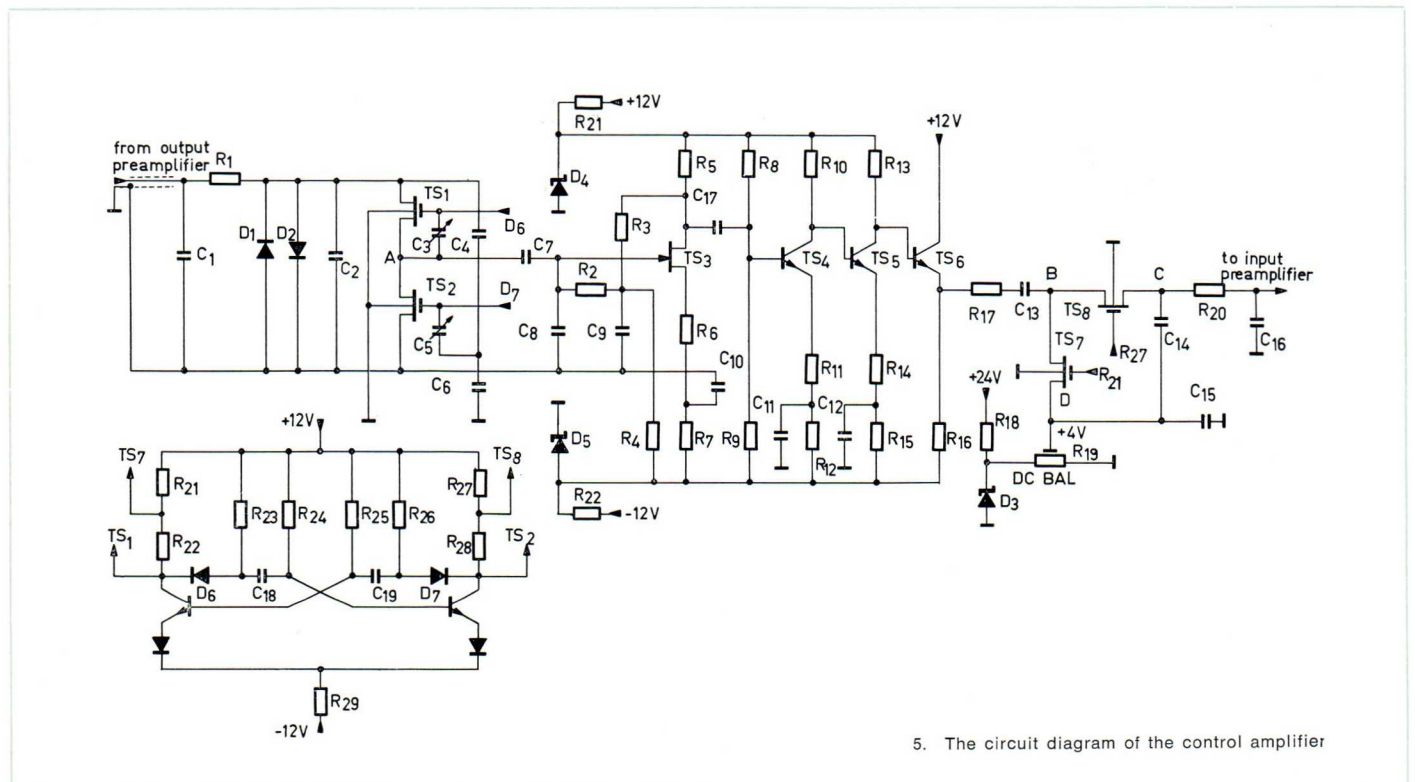

5. The circuit diagram of the control amplifier

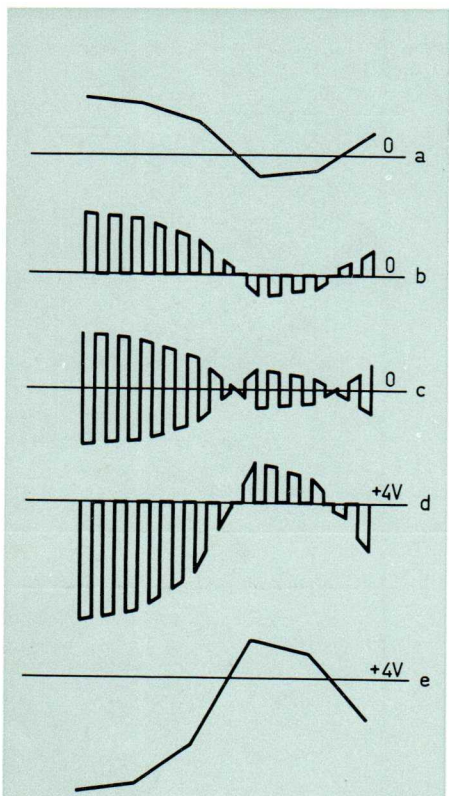

6. Waveforms associated with fig. 5. The ratio between the frequencies of square wave and envelope is chosen much too low in these figures

7. Distortion of a square-wave voltage due to (a) positive deviation from the nominal amplification ($\Delta A > 0$) and (b) negative deviation ($\Delta A < 0$)

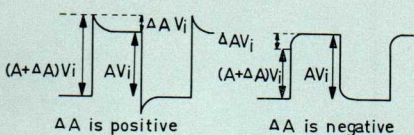

phase, produced by means of the network (C_4, C_5, C_6).

The square-wave voltage at point A gives rise to a DC voltage at the output and is thus seen as DC offset. This source of error is also eliminated with the aid of a trimmer (C_3).

The AC amplifier consists of three stages and a final emitter-follower. The first stage is a FET (TS_3), since a high input impedance is required in connection with the high resistance at the input of the chopper. The AC amplifier has an amplification factor of about 4000. Its output voltage has the form shown in fig. 6c. Because the DC component of the signal of fig. 6b is not amplified the output voltage shows a symmetrical form.

The demodulator consists of the MOSFET's TS_7 and TS_8 , with C_{13} and C_{14} . These transistors are made conducting in turn in the same frequency as TS_2 and TS_1 respectively. When TS_7 is conducting, the voltage at point B is 4 V. If TS_7 is cut off, the whole voltage jump at the emitter of TS_6 is passed to point B via C_{13} (fig. 6d). TS_8 is conducting at this moment, so that point C has the same voltage as point B. TS_7 now becomes conducting and TS_8 cuts off, so that the voltage across C_{14} cannot change. The voltage at point C thus follows the envelope of the amplifier output voltage (fig. 6e).

In order to adjust the output voltage of the pre-amplifier to exactly 0 V, the voltage of 4 V at point D is made variable with the aid of R_{17} ("DC BAL" potentiometer).

The 2 kHz interference at C_{14} is removed by a low-pass filter till 10 Hz; the operating frequency range of the control amplifier is thus DC — 10 Hz. The filtered output voltage is fed to the pre-amplifier (gate TS_2 , see fig. 3 page 7). The MOSFET's are controlled by an astable multivibrator with a frequency of 2 kHz. The diodes D_6 and D_7 are included in the circuit to decouple the collectors from the capacitors when the transistors are cut off, so

that the top of the switching signal remains flat.

Another effect of the above described correction systems is that the influences of variations in the pre-amplifier gain are also reduced.

If the amplification of the pre-amplifier varies by an amount ΔA , then in the absence of the control amplifier the output voltage would vary by $-\Delta A V_i$. However, the presence of the control amplifier reduces this output variation. If we call the real output variation ΔV_o ,

$$\text{then } \Delta V_2 = \frac{-B}{2A} \Delta V_o$$

$$\text{and } \Delta V_o = A \Delta V_2 + \Delta A (\Delta V_2 - V_i)$$

so

$$\Delta V_o \left(1 + \frac{B}{2} + \frac{B}{2A} \Delta A \right) = -\Delta A V_i$$

$$\text{or: } \Delta V_o = \frac{-\Delta A}{1 + \frac{B}{2} + \frac{B}{2A} \Delta A} V_i =$$

$$= \frac{-\Delta A}{1 + \frac{B}{2} \left(1 + \frac{\Delta A}{A} \right)} V_i$$

For small ΔA , therefore, the variation of the output voltage is reduced by a factor $(1 + B/2)$ by the control amplifier, and will thus be negligible.

The above argument holds for low frequencies. Since the control amplifier only responds (relatively) slowly to abrupt changes, a step function applied to the input of the pre-amplifier will initially be amplified by $(A + \Delta A)$, and ultimately by A . A LF square-wave voltage will thus appear at the output as shown in figure 7 if A is incorrectly set.

This error can be got rid of by adjusting the amplification of the pre-amplifier to the proper value by means of R_4 and R_5 (see fig. 3 page 7).

Trigger amplifier

by P. M. v. Cuijk

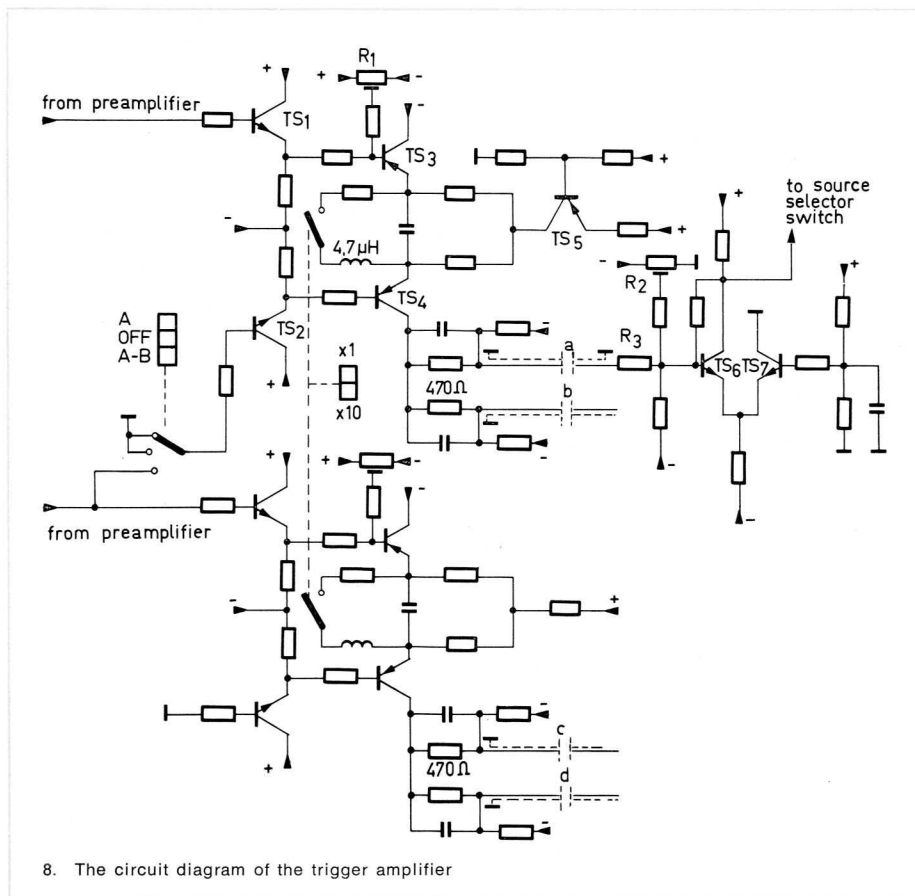

8. The circuit diagram of the trigger amplifier

The circuit diagram of the trigger amplifier is shown in fig. 8. This circuit consists of two amplifiers, one of which is connected to the pre-amplifier output of channel A and the other with that of channel B. When the channel selector switch A-OFF- (A-B) is set to A-B, the input of the channel A trigger amplifier which is otherwise earthed is connected to channel B. The channel A trigger amplifier then works as a differential amplifier. In order to improve the differential action, a current source is connected with the emitter circuit of this stage by means of transistor TS₅.

Since the two amplifiers are otherwise identical, we shall only describe the oper-

ation of channel A trigger amplifier here. It should be remarked that the same circuit follows after points b, c and d as is shown after point a

The first stage consists of two emitter-followers, to provide good decoupling from the pre-amplifier. The second stage consists of one part with current feedback and one with voltage feedback. Since only one, asymmetrical signal is required for triggering, only one side of the voltage-feedback part is realized. The trigger signal must be fed to both the main base and the delayed time base. In order to ensure good transmission of these signals, they are conveyed terminated by 50-ohm

cables. This can be done without special measures by connecting the current-feedback and voltage-feedback parts by a similar cable, and by increasing the input impedance of the voltage-feedback part to 50 ohm by means of R₃. In fact, one voltage-feedback part is provided for the main time base, and another for the delayed time base, both of which are fed by the transistor TS₄ with current feedback. The 470-ohm collector resistance of TS₄ ensures uniform current distribution.

From the collector of TS₆, the signal passes to the source selector switch (with position Y_A, Y_B, EXT.). The DC output level can be adjusted by means of the potentiometer R₂. Transistor TS₇ gives TS₆ a low emitter impedance.

When the gain selector switch of the amplifier is in position x10, the output signal of the pre-amplifier is only 6 mV/div instead of 60 mV/div. In order to maintain the same trigger sensitivity, the trigger amplifier must amplify 10x more. This is realized by reducing the feedback in the emitter leads of TS₃ and TS₄, by means of a resistor shunted across the feedback resistors of these transistors. The emitter voltages of TS₃ and TS₄ can be equalized by means of the potentiometer R₁, so that the DC collector voltage of TS₆ does not alter when we switch from one gain range to another.

Since the bandwidth of the vertical amplifier is reduced to 5 MHz with the gain selector at x10, a self-inductance of 4.7 μH is included in series with the above-mentioned series resistor. This reduces the bandwidth of the trigger amplifier so that trouble due to noise and interference signals for triggering is minimized.

Switching amplifier

by P. M. v. Cuijk

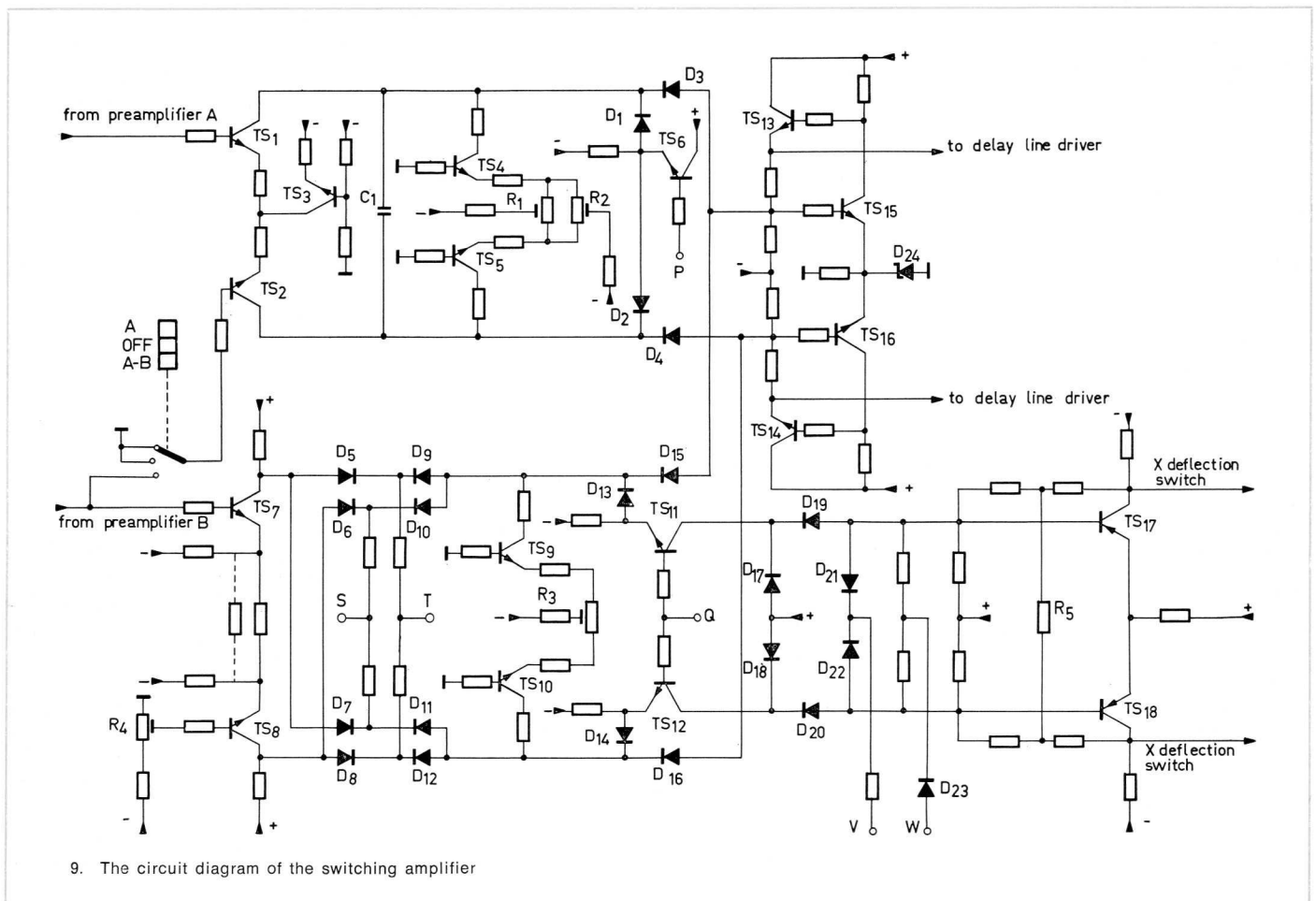

9. The circuit diagram of the switching amplifier

This comprises the circuits (fig. 9) between the pre-amplifiers and the delay-line driver, namely the Y_A and Y_B amplifiers, the electronic switch and the horizontal pre-amplifier.

Channel A

This contains a push-pull amplifier. When the channel selector switch (A-OFF-(A-B)) is set to A, one of the inputs of this amplifier is connected to the A pre-amplifier, while the other is earthed via a reed relay. When the channel selector switch B-OFF-

(-B) is at OFF the base voltage of transistor TS_6 (point P) is such that the diodes D_1 and D_2 are cut off, while diodes D_3 and D_4 are conducting. The channel A amplifier now contains transistors TS_1 and TS_2 with current feedback and TS_{15} and TS_{16} with voltage feedback.

A small part of the current for the voltage-feedback section is provided by transistors TS_4 and TS_5 . This current can be varied by means of the potentiometer R_1 , in such a way that when the current in one arm increases, that in the other arm decreases.

The emitter voltages of TS_{13} and TS_{14} vary correspondingly; this thus gives us a way of adjusting the vertical position of the image. The potentiometer R_2 can be adjusted so that when R_1 is in its middle setting, the image is in the middle of the screen.

The capacitor C_1 is connected between the collectors of TS_1 and TS_2 in order to make this channel identical with channel B for high frequencies. The capacitance here corresponds to the capacitance formed by the diodes D_5 - D_{12} between the collectors

of TS₇ and TS₈ in channel B.

When the switch A-OFF-(A—B) is at OFF, the base voltage of TS₆ (point P) is such that the diodes D₁ and D₂ are conducting, while D₃ and D₄ are cut off. The signal is now blocked.

In position "A—B", the input of the amplifier which was earthed is connected to the output of the pre-amplifier of channel B instead. This makes channel A differential. The differential action is improved by feeding the emitter resistors of TS₁ and TS₂ via the transistor TS₃. The base voltage of TS₆ (point P) is again such that diodes D₁ and D₂ are cut off, while D₃ and D₄ are conducting. For the case when the switch B-OFF-(—B) is not off, see the section on the electronic switch.

Channel B

When the switch B-OFF-(—B) is at B, the voltage at the point T is such that diodes D₅, D₉, D₈ and D₁₂ are conducting. The voltage at point S is such that diodes D₆, D₁₀, D₇ and D₁₁ are cut off. Further, if the switch A-OFF-(A—B) is at OFF under these conditions, then the base voltages of TS₁₁ and TS₁₂ (the voltage at the point Q) is such that diodes D₁₃ and D₁₄ are cut off, while D₁₅ and D₁₆ are conducting.

The amplifier now consists of transistors TS₇ and TS₈ with current feedback and TS₁₅ and TS₁₆ with voltage feedback. When the switch B-OFF-(—B) is at OFF, the bases of TS₁₁ and TS₁₂ (point Q) receive such a voltage that diodes D₁₃ and D₁₄ are conducting, while D₁₅ and D₁₆ are cut off. The signal is now blocked.

When the switch is set to "—B", then diodes D₆, D₁₀, D₇ and D₁₁ are conducting, while D₅, D₉, D₈ and D₁₂ are cut off. This has the effect of reversing the signal leads, as it were. Potentiometer R₄ is adjusted so that no DC voltage shift occurs on switching from "B" to "—B". The position control is the same as for channel A, except that potentiometer R₂ is missing here; its role is taken over adequately by R₄.

The signal for the delay-line driver is taken off via the emitter-followers TS₁₃ and TS₁₄, which also deliver the current for the feedback resistances of TS₁₅ and TS₁₆. This has the advantage that the collector resistances of TS₁₅ and TS₁₆ can be much larger, so that the transistor properties are not so critical for the amplification.

Electronic switch

If both the channel switches are on, the electronic switch comes into operation, and channels A and B are connected in turn. This can be done in two different ways, depending on the setting of the ALT.-CHOPP. switch.

In the chopped position, the change from channel to channel is independent of the time base; while in the alternate position channel A is connected during one sawtooth, and channel B during the next. For details of the control of the electronic switch, see page 14.

If either channel A or channel B is connected to the voltage-feedback section, the emitter voltage of TS₁₅ and TS₁₆ lies below the Zener voltage of D₂₄, so that this diode does not come into operation. If both channels are switched off, then D₂₄ limits the rise of the base voltage of TS₁₅ and TS₁₆, and the diodes D₃, D₄, D₁₅ and D₁₆ remain cut off. The two voltages to the delay-line driver are practically equal, so that a line is produced more or less in the middle of the screen.

Horizontal pre-amplifier

When the X-deflection switch (MAIN TB, DEL'D TB, EXTERN) is set at EXTERN channel B is connected to the horizontal amplifier. The base voltage of TS₁₁ and TS₁₂ (point Q) and the voltage of D₂₃ (point W) are then such that the diodes D₁₃, D₁₄, D₁₉ and D₂₀ are conducting. The amplifier now consists of transistors TS₇ and TS₈ with current-feedback which are connected via TS₁₁ and TS₁₂ to the transistors TS₁₇ and TS₁₈ with voltage feed-

back. The amplification can be adjusted by means of a trimming resistor R₅, which joins the half-way points of the two feedback resistors (each of which in fact consists of two separate resistors).

The signal passes from the collectors of TS₁₇ and TS₁₈ via the X-deflection switch to the horizontal amplifier. The B-channel position and polarity controls remain active, but the horizontal position control is put out of action by the X-deflection switch.

When the B-OFF-(—B) switch is at OFF, the voltage at point V is such that diodes D₂₁ and D₂₂ become conducting while D₁₉ and D₂₀ are cut off; the signal is thus blocked.

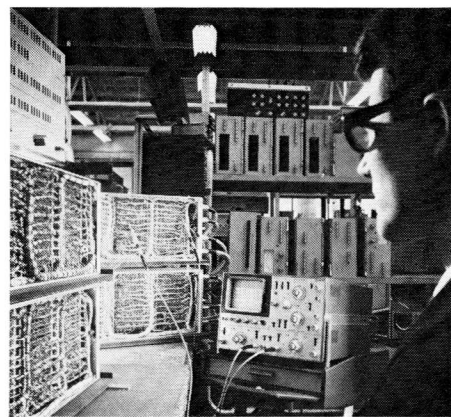

Blocking oscillator and multivibrator

by P. M. v. Cuijk

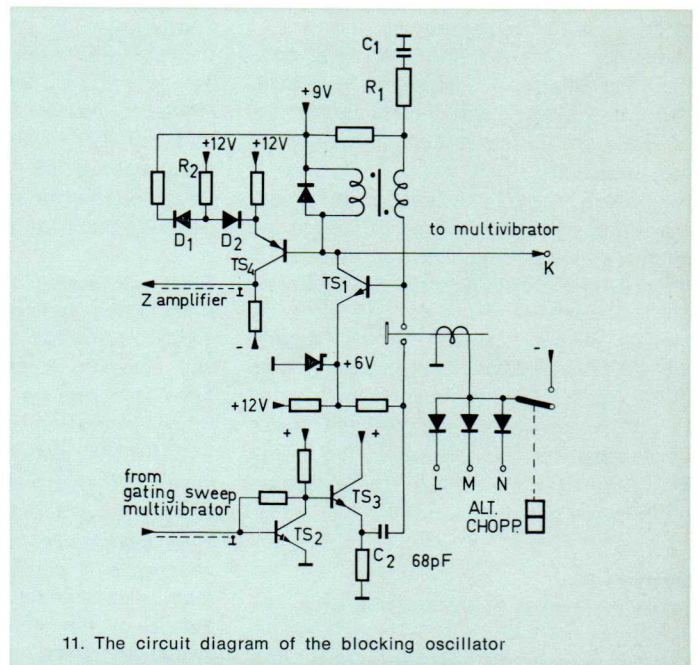
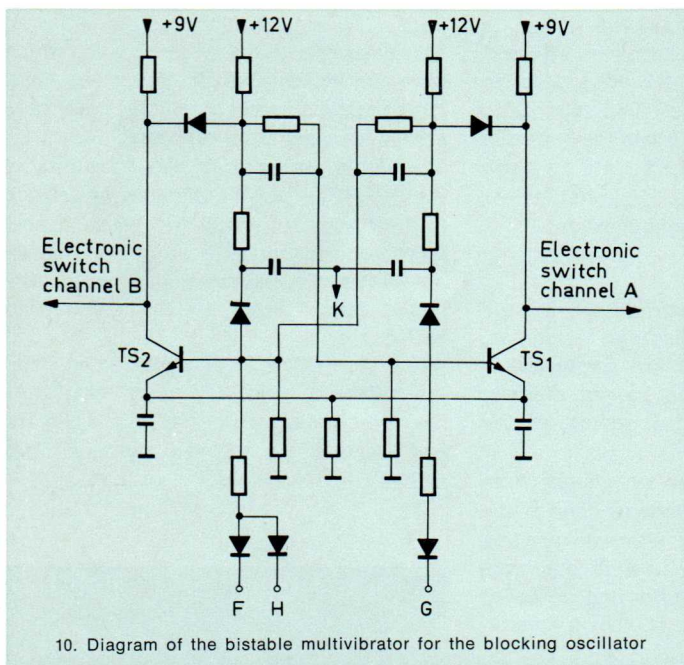

The electronic switch of the amplifier is controlled by a bistable multivibrator, the circuit diagram of which is shown in fig. 10. One output of the multivibrator is connected to point P of the electronic switch (in channel A), while the other output is connected to point Q (in channel B).

The multivibrator is controlled in its turn by the blocking oscillator of fig. 11. With the ALT.-CHOPP. switch at CHOPPED, this oscillator oscillates without triggering, at a frequency determined by the combination of R_1 and C_1 in the base lead of transistor TS_1 . The collector of TS_1 produces a steep negative pulse which is fed to the multivibrator at point K; each time the multivibrator receives such a pulse, it switches over.

With the selector switch at ALT., the base of TS_1 is connected to the +6 V supply by a reed relay, and the oscillator is locked. A current produced by a negative pulse

from the time base is now fed to the transistor TS_2 , which has voltage feedback. This current gives rise to a negative pulse at the collector of TS_2 which is applied via the emitter-follower TS_3 and C_2 (68 pF) to the base of TS_1 . Differentiation of this gives rise to a positive pulse during the flyback of the saw-tooth, thus producing a negative switching pulse at the collector of TS_1 for the control of the multivibrator. The negative pulses from the collector of TS_1 are also fed to the base of TS_4 . The current through R_2 which originally flowed through D_1 will now pass through D_2 and TS_4 to the Z modulator, via a delay line which gives the same delay as that in the vertical channel. This suppresses the signal produced during the switching between A and B, especially when the selector switch is at CHOPP.

If the switches A-OFF-(A—B) and B-OFF-(—B) are both on, and the X DEFL. switch is not at EXT., then the blocking oscillator

is not locked, and the electronic switch passes channel A and channel B alternately.

When the B-OFF-(—B) switch is off, the reed relay is actuated via point L, and the blocking oscillator is locked. At the same time, TS_2 receives via point F a base voltage such that this transistor is cut off. TS_1 now draws current, and the collector voltage of this transistor is such that channel B is blocked.

When the A-OFF-(A—B) switch is off, the relay is actuated via point M, and TS_1 is cut off at the same time via point G. Now channel A is blocked.

If both switches are off, both transistors of the multivibrator are cut off, so that both amplifier channels are blocked.

When the X DEFL. switch is at EXT., the blocking oscillator is locked via point N, channel A is open because TS_2 is cut off via point H. Channel B is connected to the horizontal amplifier, via point V, see fig. 9

Delay line driver, delay line and terminating amplifier

by P. M. v. Cuijk

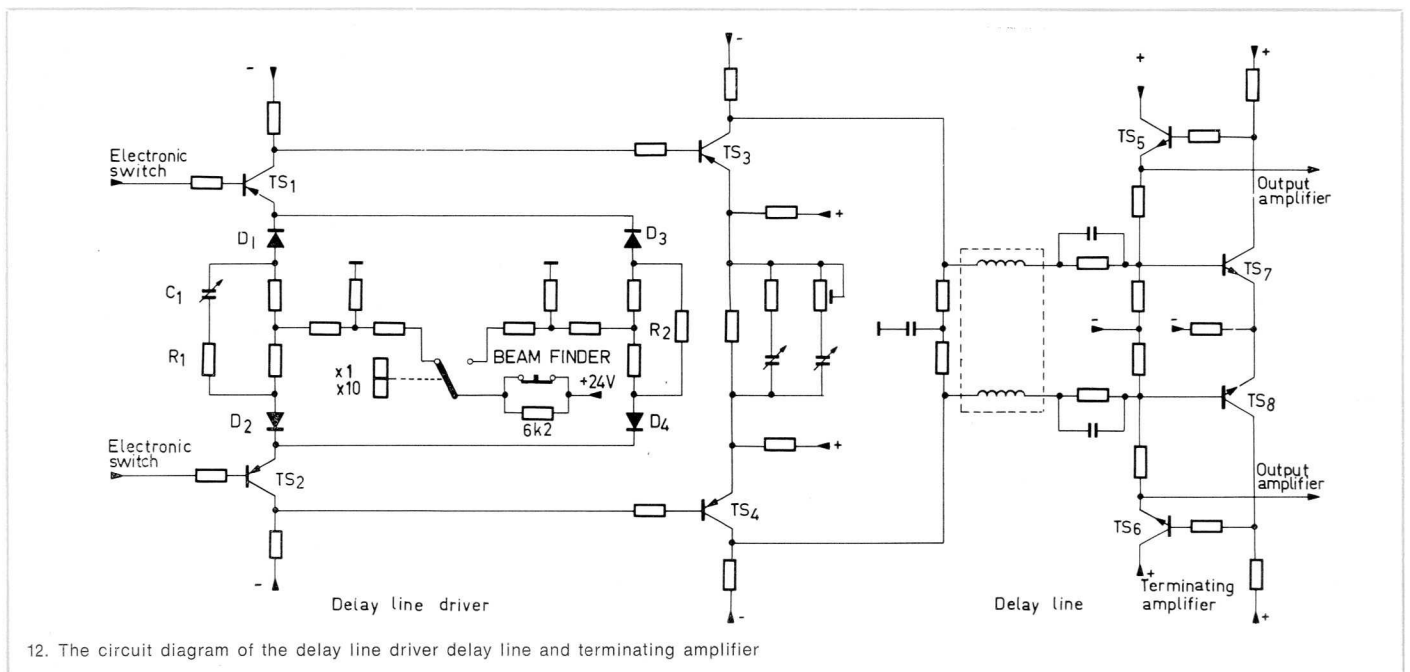

12. The circuit diagram of the delay line driver delay line and terminating amplifier

The circuit diagram is shown in fig. 12. The first stage is a normal push-pull amplifier, whose function is to increase the sensitivity of the whole section by a factor of 10 when the gain switch is in its x10 position.

With the gain switch at x1, the diodes D_1 and D_2 connect resistors in the emitter leads of TS_1 and TS_2 such that the overall amplification factor of the section is 1. Diodes D_3 and D_4 are cut off. The R_1C_1 time constant of the emitter leads ensures optimum transmission of the highest frequencies.

With the gain switch at x10, diodes D_1 and D_2 are cut off, and D_3 and D_4 are conducting. The emitter resistances are now such that the section gives an amplification of 10x. The trimming resistor R_2 can be used to give the final adjustment to the amplification.

The current for this stage is taken from the +24 V supply, via a resistor (6k2) which is short-circuited in the normal oper-

ating position. This short-circuit is realized with the beam-finder push-button in its quiescent position. When this button is depressed, the 6k2 resistance is inserted into the circuit, and the current in the stage is drastically reduced. The deflection is then very slight, and the image will remain on the screen, even when the position controls are operated.

The second stage is also built as a push-pull amplifier, and consists of two parts. The first part has current feedback and the second has voltage feedback; the delay line is connected between these two parts. This delay line is terminated at both ends by its characteristic impedance (50 ohm). Two RC combinations are shunted across the emitter resistor between TS_3 and TS_4 , to compensate for the losses in the delay line.

The signal for the final amplifier is taken from the collectors of TS_7 and TS_8 via emitter-followers TS_5 and TS_6 , which also provide the current through the voltage-feedback resistors.

Construction of delay line

by F. Govaerts

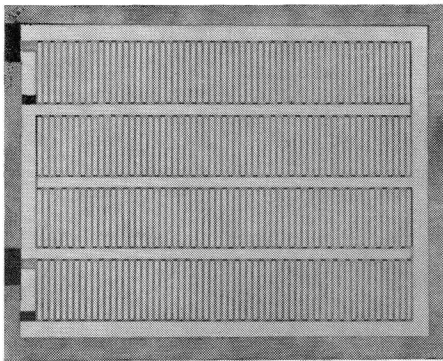

13. Printed circuit forms the hart of the delay line

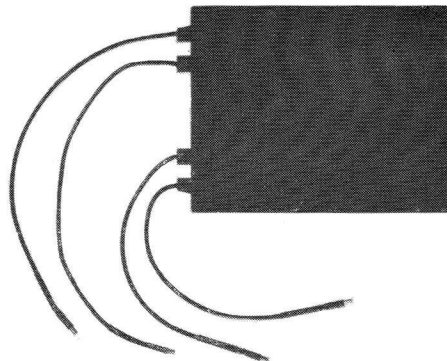

14. The complete delay line

The delay line of the PM 3250 consists of a double-clad print on an epoxy base (see fig. 13). Its characteristic impedance is 50 ohm and the total delay time 65 nano-sec. After the 50-ohm leads have been connected, the delay line is encapsulated in plastic (fig. 14). This delay line is only suitable for 2 input signals which are in anti-phase.

The conducting tracks are designed so that current loops are produced (see fig. 15). As may be seen from the figure, current loop 1 is coupled with loop 2, against loop 3, etc. This gives a very high self-inductance. The self-inductance of the current loops themselves is largely determined by the coupling between the two trace patterns i.e. by the thickness of the epoxy resin.

The capacitance is formed by the interaction of the two trace patterns, and is inversely proportional to the thickness of the epoxy resin. Since both the self-inductance and the capacitance depend on the thickness of the epoxy base, variations in this thickness will have hardly any effect on Z_0 . The delay time, on the other hand, will change.

The rise time of the delay line with correction networks is about 1 ns.

The advantages of this printed delay line compared with the conventional cable type are the very good reproducibility of Z_0 , the high delay time per unit volume and the ease of mounting.

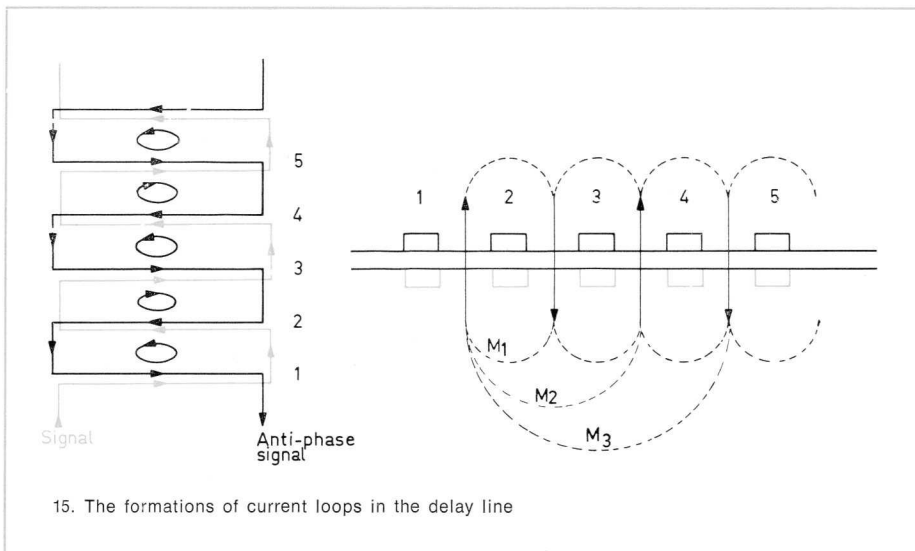

15. The formations of current loops in the delay line

Output amplifier

by F. Govaerts

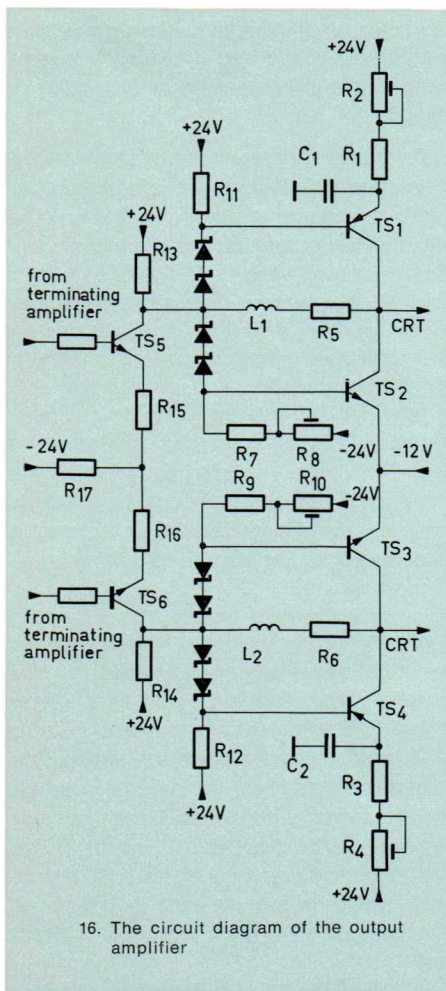

The output stage of the PM 3250 is a complementary single-ended push-pull class AB amplifier, driven by a current source. This current source consists of a stage with current feedback, which has the function of driving the output stage as well as limiting the voltage swing of the vertical amplifier, see fig. 16. This voltage swing is 20—30% greater than that required for full screen deflection. In order to avoid current and voltage distortion, this limitation is

realized at the emitters of the driving stage.

When the vertical amplifier is in the middle of its range, TS_5 and TS_6 draw the same current I .

As the modulation of the amplifier is increased, a moment will be reached where e.g. TS_5 ceases to pass current, while TS_6 will pass the full $2I$. The side of the output amplifier driven by TS_5 no longer amplifies, while the side driven by TS_6 continues to amplify. This undesirable state of affairs must be remedied, which is done with the aid of R_{17} . At the moment when TS_5 ceases to pass current, R_{17} will be included in the path followed by the signal. The current feedback will now be increased, with the result that the amplification of the output stage is reduced by a factor of 10.

The quiescent current of TS_5 and TS_6 is delivered via the resistors R_{13} and R_{14} . The output stage is based on the principle that a transistor with voltage feedback has a very low input resistance (of the order of r_e of the transistor) as a result of this feedback. A complementary transistor is used as collector resistance; this is also driven by the driver stage. This complementary transistor is connected in such a way that it can in its turn be regarded as a transistor with voltage feedback, with the other transistor as its collector impedance. The collectors of the transistors are thus connected, and this common point is also the output of the amplifier. The result of this is that both transistors have the same feedback resistor; as a result of the opposite polarity, the quiescent current of the feedback resistor is thus zero. Now since the transistors of the output stage do not have to supply any quiescent current at all to the circuit, the quiescent current of the output stage itself can be kept very low. This quiescent current can be adjusted by means of the variable resistor R_2 in the emitter lead of TS_1 and R_4 in the emitter lead of TS_4 . The feedback gives the bases and hence also the emitters

of the output transistors a fixed potential. The voltage across $R_1 + R_2$ (and across $R_3 + R_4$) is thus also constant, so that the quiescent current of the output stage can be adjusted by varying the total value of these two resistor pairs.

C_1 and C_2 serve to eliminate the current feedback at high frequencies.

This current setting means that these transistors are not driven by low-frequency signals and DC shifts. The quiescent current of the output stage must now be adjusted so that it exceeds the maximum driving current I , to avoid current distortion. The maximum driving current and the feedback resistor determine the maximum voltage modulation, together with the knee voltages of the two transistors, represents the minimum voltage gap between the two bases, which is determined by four Zener diodes between the bases. These Zener diodes help to determine the minimum voltage modulation, and also connect the bases to the feedback resistors. In order to keep the resistance of the Zener diodes low, the resistors R_{11} (12), R_7 (9) and R_8 (10) are used to define the current through the Zener diodes so that its minimum value is equal to the maximum base current. R_8 (10) is made variable, so that the deviations from the nominal quiescent current due to the tolerances in the Zener diodes can be compensated for. The voltage across the total resistance R_7 (9) and R_8 (10) is also constant, and the current through these resistor pairs can be adjusted by means of R_8 (10).

A self-inductance is included in series with the feedback resistor to increase the bandwidth of the output amplifier. The HF boosting cannot be realized in the driver stage, as this would then be dependent on the emitter resistance values of TS_5 and TS_6 and hence on the vertical position of the image on the screen.

Functional description of the horizontal deflection system

by F. Bregman

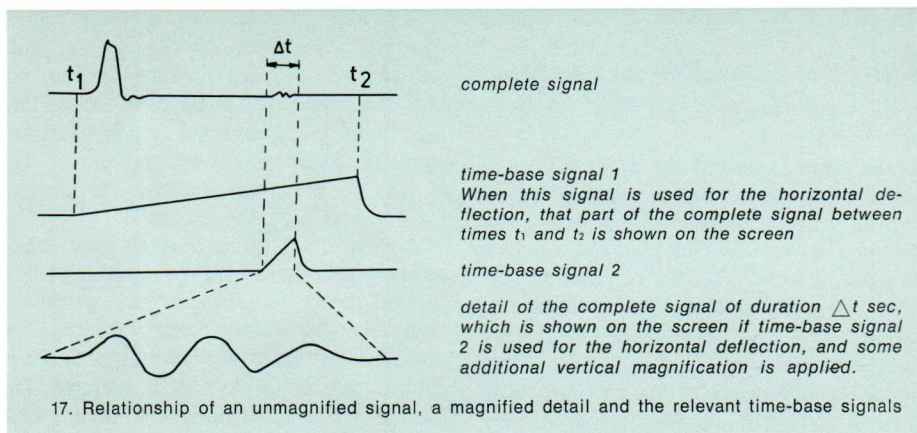

Introduction

The PM 3250 is equipped with a double time-base system in order to permit any desired magnification of a detail along the time axis. This possibility is illustrated in fig. 17, which shows an unmagnified signal and the detail magnification together with the relevant time-base signals.

Time-base signal 1 is produced by the "main time-base generator", and time-base signal 2 by the "delayed time-base generator". We shall start our description of the double time-base system with the main time-base generator.

The main time-base generator

The saw-tooth signal (time-base signal 1, fig. 17) is triggered by the signal under observation itself (taken from one of the vertical pre-amplifiers), or by another signal applied to the external trigger input. The production of a saw-tooth voltage from this trigger signal occurs in 2 phases. First of all a trigger pulse of standardized height and width is produced from the trigger signal (see the block diagram of fig. 18). This pulse now triggers the saw-tooth generator, thus determining the origin of the time axis. In order to enable this origin to coincide with any desired point of the trigger signal, the oscilloscope is provided with a trigger-level control (LEVEL) and a slope selector switch

which allows triggering on both the positive-going and negative-going edges of the trigger signal.

After selection of the desired trigger signal by means of the selector switch source (see fig. 18), the transfer characteristic of the system can be reduced to remove interfering frequency components, such as hum or noise, from the trigger signal. The frequency range employed can be chosen by means of the switch coupling: in the position LF, the range from 3 Hz to 1 MHz is selected, and in position HF the range from 2 kHz to well above 50 MHz. In the position DC (0 to well above 50 MHz), the trigger signal is passed unchanged. The difference amplifier now amplifies the difference between the trigger signal and the DC voltage from the potentiometer LEVEL, and the output signal of this amplifier is fed to the trigger multivibrator. The sign of the amplification is selected with the aid of the switch slope. The operation of the whole system is illustrated in fig. 19.

ΔV_1 represents the dynamic range of the difference amplifier. Input signals falling within this range produce amplified output signals. When these output signals overlap the hysteresis gap ΔV_2 of the trigger multivibrator, square-wave signals are produced at the output of the latter; after differentiation, these square-wave signals give short positive and negative pulses. In the PM3250 the negative pulses produced at the output of the differentiating circuit are used for the triggering of the saw-tooth generator; the positive pulses are used for the control of an automatic free-run circuit, as described further on in this article.

As may be seen from fig. 19, when the slope switch is in its "+" position the saw-tooth generator is triggered by the positive-going edge of the original trigger signal, and when the slope switch is in its "-" position by the negative-going edge. The precise point on the edge in question which triggers the time base can be selected with the LEVEL control. The LEVEL potentiometer is fitted with a pull-push switch which allows a 5 fold range increase to be used for large trigger signals.

As may be seen from fig. 20, the saw-tooth generator proper consists of a Schmitt trigger (from now on referred to as the SGM - sweep gating multivibrator), an integrator and a hold-off circuit.

The input signal of the SGM is made up of three separate signals, of which we shall ignore that from the automatic free-run circuit for the moment. If the SGM is triggered by the trigger pulse, a voltage step is applied to the input of the integrator, with the result that a voltage increasing linearly with time is produced at the output of the integrator. As soon as

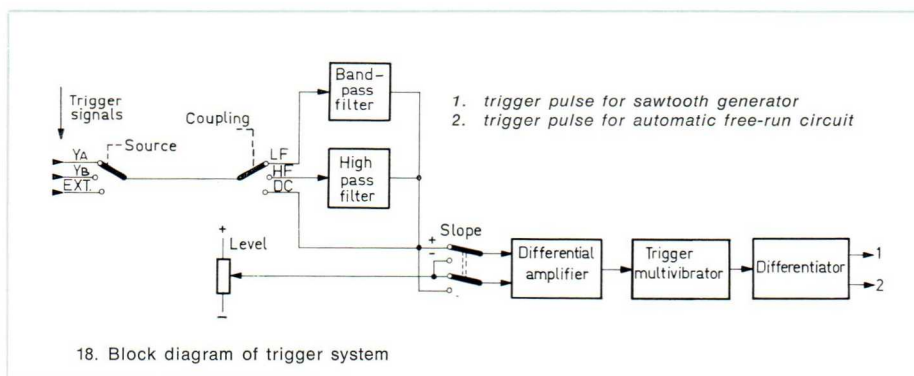

this voltage reaches a level determined by the hold-off circuit, the latter is triggered, producing a pulse whose width is correlated with the rate of increase of the integrator output signal. The hold-off circuit can thus be regarded as a monostable multivibrator, one of whose time-determining elements is adjustable and coupled with the integrator. The hold-off pulse, produced by the hold-off circuit, switches the SGM back to its original state, as a result of which the output voltage of the integrator — which is the time-base signal — falls relatively quickly to its original value. This process is illustrated in fig. 21.

The quiescent level of the SGM input signal is within the hysteresis gap; the starting pulse takes the input level below the lower limit of this gap, and the hold-off

pulse above the upper limit. The height of the hold-off pulse is chosen so that if it should coincide with a trigger pulse the latter will have no effect; this prevents a new saw-tooth signal from being initiated before the integrator has been fully discharged. For this reason also, the duration of the hold-off pulse ($t_4 - t_2$) should be appreciably greater than the discharge time of the integrator ($t_3 - t_2$).

The slope of the saw-tooth voltage and hence the horizontal scanning speed can be varied stepwise and continuously by changing the magnitude of the time-determining elements in the integrator.

In order to prevent the presence of a stationary spot on the left of the screen in the absence of a saw-tooth signal, which could damage the phosphor and to

prevent the flyback from producing a visible trace on the screen (between times t_2 and t_3 , see fig. 21), the control grid (Wehnelt cylinder) of the cathode ray tube is controlled by a positive pulse (the "un-blanking" pulse) superimposed on a DC voltage which alone would suppress or blank the electron beam. The pulse in question should be present between the times t_1 and t_2 , and is thus derived from the SGM output.

The mode of operation described above is produced when the trigger mode selector is set to TRIGG. This selector also has two other positions — SINGLE, for single-sweep operation and AUTO, in the case of which the automatic free-run circuit is operative. When events which occur only have to be observed (and generally photographed), it is often desirable to ensure that only one saw-tooth is generated, even though several trigger pulses might be produced after the phenomenon of interest. Of course, the single saw-tooth in question must be triggered by a trigger pulse.

In order to realize this, the hold-off circuit is changed from a monostable multivibrator to a bistable, so that when the peak value of the saw-tooth voltage is reached the hold-off circuit produces not a pulse but a voltage step, thus switching the SGM back to its quiescent state and blocking it for further trigger pulses. The hold-off circuit can be switched back by the SET READY push-button, after which the next trigger pulse received will again lead to the production of one single saw-tooth. If the trigger mode selector is set to AUTO, the saw-tooth generator again works as illustrated in fig. 21 and as described above for TRIGG, except that now the automatic free-run circuit is switched on. As already indicated in fig. 18 and 20 the automatic free-run circuit, generally named AUTO circuit, is controlled by trigger pulses, and it in its turn controls the SGM. The function of this circuit is to ensure that the saw-tooth generator is free-running in absence of trigger pulses. This means that, as soon as one saw-tooth is completed (at time t_4 , fig. 21) a new one is generated.

In this way an image, though not a stationary one, is always produced on the screen, even though the trigger controls (source, level, slope, coupling) may not be correctly adjusted. This facilitates the search for the correct adjustment of the oscilloscope.

The AUTO circuit contains a capacitor which is connected to the SGM via a diode. This capacitor is discharged to a certain voltage each time a trigger pulse is detected.

The polarity of this voltage is chosen so that when it is present, i.e. when a trigger pulse has been received, the diode is cut

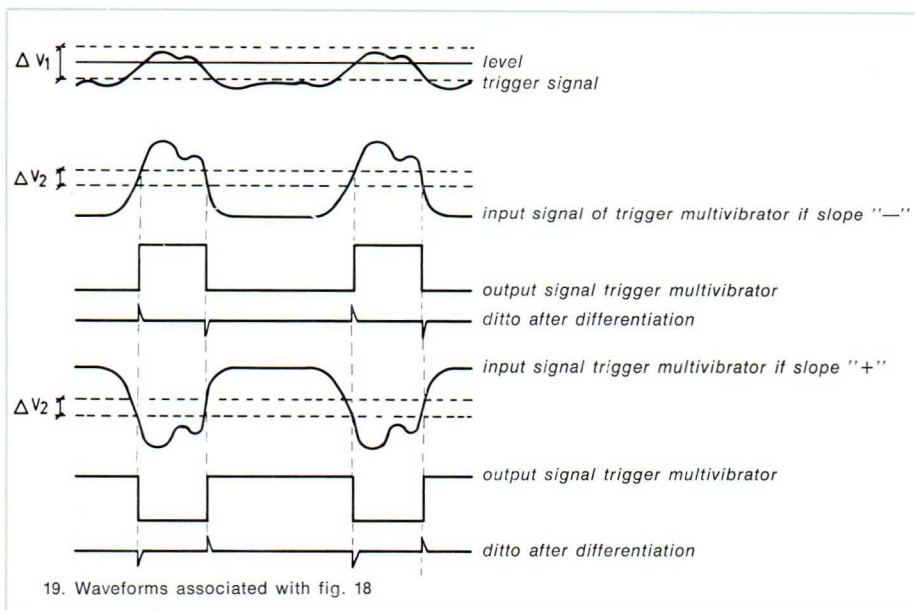

19. Waveforms associated with fig. 18

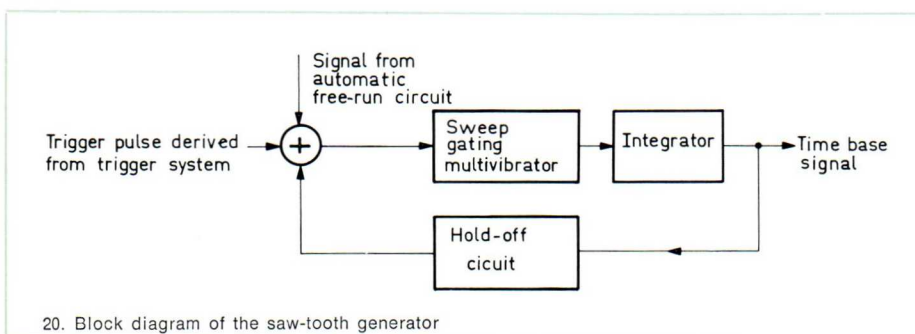

20. Block diagram of the saw-tooth generator

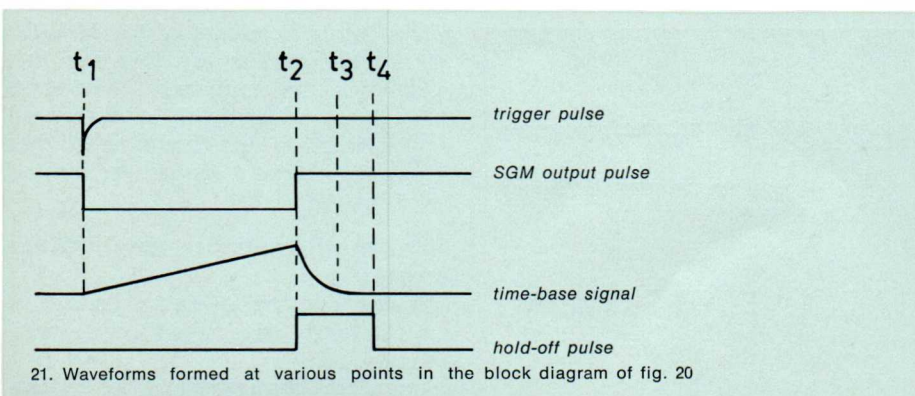

21. Waveforms formed at various points in the block diagram of fig. 20

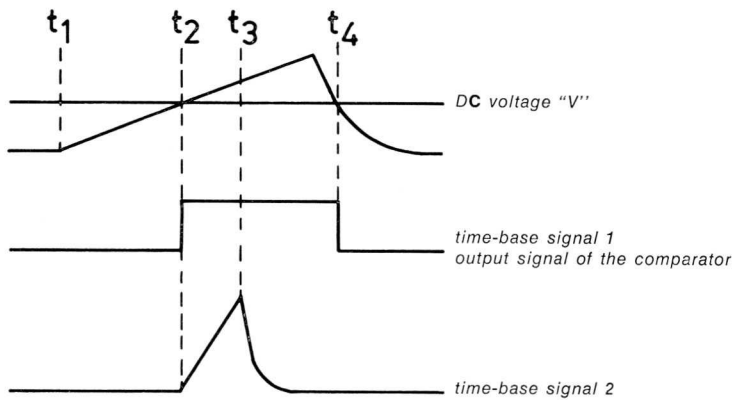

22. Waveforms formed when time-base signal 2 is started (STARTS) after delay time

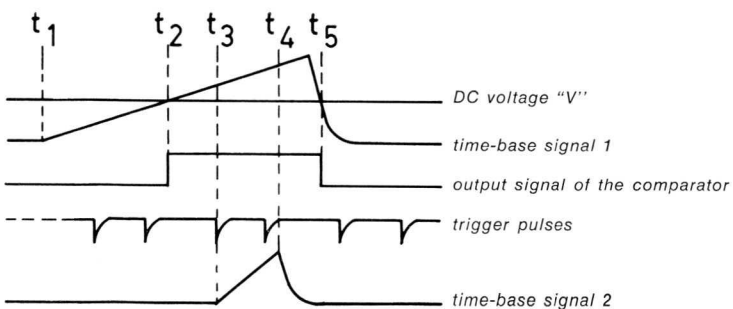

23. Waveforms formed when time-base signal 2 is triggered (TRIGG.) after delay time

off and the process sketched in fig. 21 continues unchanged. However, in the absence of trigger pulses the voltage across the capacitor will rise until, in about 0.5 sec, the diode will start conducting.

The input level of the SGM now comes to lie below the hysteresis gap. As a result, about 0.5 sec after the last trigger pulse the SGM will automatically switch over. It will be switched back by the next hold-off pulse, (which still comes above the hysteresis gap), and once again automatically switches over when the hold-off pulse is completed. This process is then repeated continuously till a new trigger pulse is received.

The delayed time-base generator

Time-base signal 2 (see fig. 17) is produced by the delayed timebase generator.

The starting moment of this signal is controlled by time-base signal 1 together with a variable DC voltage "V", adjusted with the aid of a multiturn potentiometer, the DELAY-TIME MULTIPLIER. There are two modes of operation, illustrated in fig. 22 and 23, and corresponding to positions STARTS and TRIGG respectively of the selector switch marked AFTER DELAY TIME.

The trigger circuits which come into operation when the AFTER DELAY TIME switch is at TRIGG are identical with those of the main time-base generator. The hold-off circuit of the saw-tooth generator works as described above for the main time-base generator in the SINGLE position. However, the hold-off circuit is no longer set by the SET READY push-button, but by the comparator mentioned in fig. 22 and fig.

The starting signal for the delayed sawtooth generator is derived from the time-base signal 1 and the DC voltage "V" with the aid of a difference amplifier, the comparator. By suitable adjustment of "V", any desired point on time-base signal 1 can be taken as the start of time-base signal 2. Since both the main scale of the multiturn potentiometer and the horizontal deflection scale on the CRT screen are divided into 10, the delay time t_2-t_1 can be found by multiplying the reading of the multiturn potentiometer by the setting of the TIME/div control of the main time base.

While in the previous case (fig. 22) the delayed time-base generator started directly at time t_2 , now it awaits receipt of the next trigger pulse. This method is made use of if time jitter would give a blurred picture of the detail in question (see fig. 17). This time jitter could be present in the original signal under investigation itself or — at extreme magnifications — be due to the time-base circuits in question. It goes without saying that the value of t_3-t_1 can no longer be read off from the helipot scale, and the delay time is no longer continuously variable. The delayed time-base unit has separate trigger circuits, so that if desired it can use another trigger signal and/or trigger control settings (level, slope, coupling) than the main time base.

23. (In this article, we neglect the fact that the hold-off circuit is also controlled by the SGM signal from the main time-base generator, together with the comparator signal via the reset multivibrator. This is dealt with in more detail on page 24)

The hold-off circuit returns to its original state at time t_2 (see fig. 22 and 23). With the AFTER DELAY TIME switch at STARTS (fig. 22), the input voltage of the SGM falls to below the hysteresis gap, so that the SGM is triggered immediately, and the time-base signal 2 starts at time t_2 . In the other mode of operation (TRIGG, fig. 23), the input voltage of the SGM is also reduced at time t_2 but not so much: it now lies within the hysteresis gap. The next trigger pulse which is received will thus trigger the SGM. Here again, when time-base signal 2 reaches its peak value the hold-off circuit is switched to the state where the input voltage of the SGM lies above the hysteresis gap. This also happens when the comparator signal ends (t_4 in fig. 22 or t_5 in fig. 23) or at the start of the flyback of time-base signal 1, even if time-base signal 2 has not yet reached its peak value.

Selection of X-deflection and brightness control

The results of two different selections of the X-deflection have already been sketched in fig. 17:

A. with time-base signal 1 for the horizon-

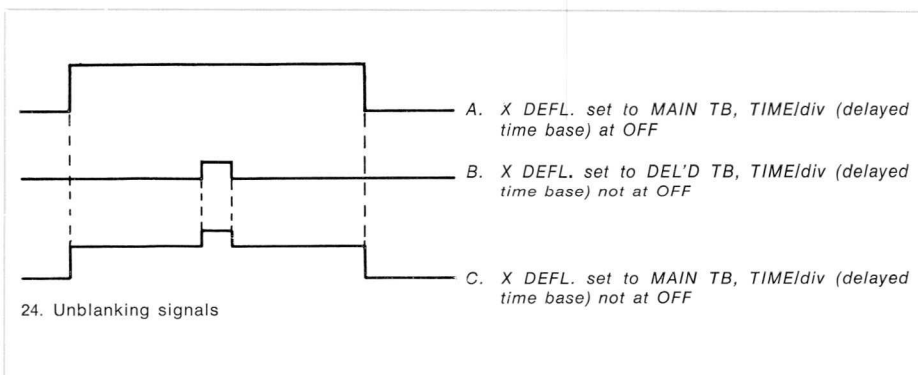

tal deflection and the SGM signal from the main time-base generator as unblanking pulse; and

B. with the corresponding signals from the delayed time-base generator.

However, the correct adjustment of the DELAY TIME MULTIPLIER and TIME/div controls in order to observe the time interval Δt is greatly facilitated by a third possibility:

C. in which the time-base signal 1 provides the horizontal deflection (so that the complete signal is displayed on the screen), while the signal intensity is increased during the presence of the delayed saw-tooth. The unblanking signal is here a combination of the pulses from the two sweep gating multivibrators, as shown in fig. 24. The positions of the X DEFL. and TIME/div controls (delayed time base) corresponding to these three possibilities are also given in fig. 24.

With the X DEFL selector switch in its third position, EXTERN via Y_B , the horizontal deflection amplifier is not connected to one of the time-base generators, but to the vertical B channel (for XY measurements). In these measurements, the same extensive control possibilities exist for both deflection directions, except that the x10 magnification is only operative for the vertical deflection.

The horizontal deflection amplifier

The horizontal deflection amplifier is equipped with a potentiometer (X POSITION) with the aid of which the image on the screen can be displaced horizontally. This potentiometer has a pull-push switch (X MAGN.) which can be used to increase the amplification by a factor of 5 (so that the values on the TIME/div scale are reduced by a factor of 5). This facility can be used instead of the delayed time base for detail studies of signals — although of course its scope is more limited (see page 38).

The X-magnification and positioning controls are switched off for XY measurements, as these facilities are already present in the Y_B channel.

Ergonomy and design

We have now dealt (explicitly or implicitly) with all the controls used for adjustment of the horizontal deflection. This information is summarized in the following table. It will be clear from the number of these controls (20 in all), if from nothing else, that a complete double time-base system makes the operation of the oscilloscope as a whole appreciably more complicated. The best solution of this problem of control complexity is to arrange the controls logically, in straight lines, and as conveniently positioned as possible. For these reasons, the PM 3250 is e.g. not equipped with multiple function time-base sweep-

No.	Name of control *)	Positions or range	Function
1.	Mode	AUTO, TRIGG. SINGLE	selection of mode of main time-base generator
2.	Source	Y_A , Y_B , EXT	selection of triggering source for main time-base generator
3.	Coupling	LF, HF, DC	selection of trigger-signal coupling for main time-base generator
4.	TIME/div or DELAY TIME	1 s to 0.05 μ s	step control of time scale of main time-base generator
5.	ditto	———— CAL	continuous control of time scale of main time-base generator
6.	Slope	+ —	slope selection of trigger signal for main time-base generator
7.	LEVEL		selection of triggering level of trigger signal for main time-base generator
8.	ditto	PULL FOR X5	increases range of level control (7)
9.	DELAY TIME MULTIPLIER	vernier 0—10	determines delay time, in combination with (4) and (5)
10.	AFTER DELAY TIME:	STARTS, TRIGG.	selection of mode of delayed time-base generator
11.	Source	Y_A , Y_B , EXT.	selection of triggering source for delayed time-base generator
12.	Coupling	LF, HF, DC	selection of trigger-signal coupling for delayed time-base generator
13.	TIME/div	0.5 s to 0.05 μ s OFF	step control of time scale of delayed time-base generator, and OFF switch
14.	ditto	———— CAL	continuous control of time scale of delayed time-base generator
15.	Slope	+ —	slope selection of trigger signal for delayed time-base generator
16.	LEVEL		selection of triggering level of trigger signal for delayed time-base generator
17.	ditto	PULL FOR X5	increases range of level control (16)
18.	X DEFL.	MAIN T B DEL'D T B, EXT	selection of source for X deflection
19.	X POSITION		horizontal position control
20.	X MAGN.	PULL FOR X5	horizontal amplification control

*) These are the names used in the text; those in capitals are also used on the control panel of the oscilloscope; see photo, fig. 25

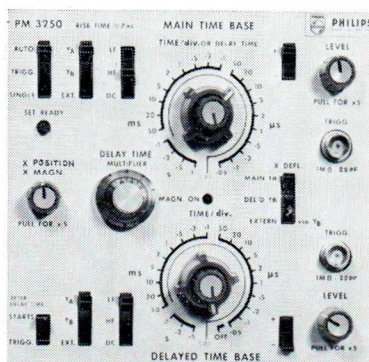

25. Part of the control panel, containing all horizontal deflection controls

The automatic free-run circuit

by A. W. Goossens

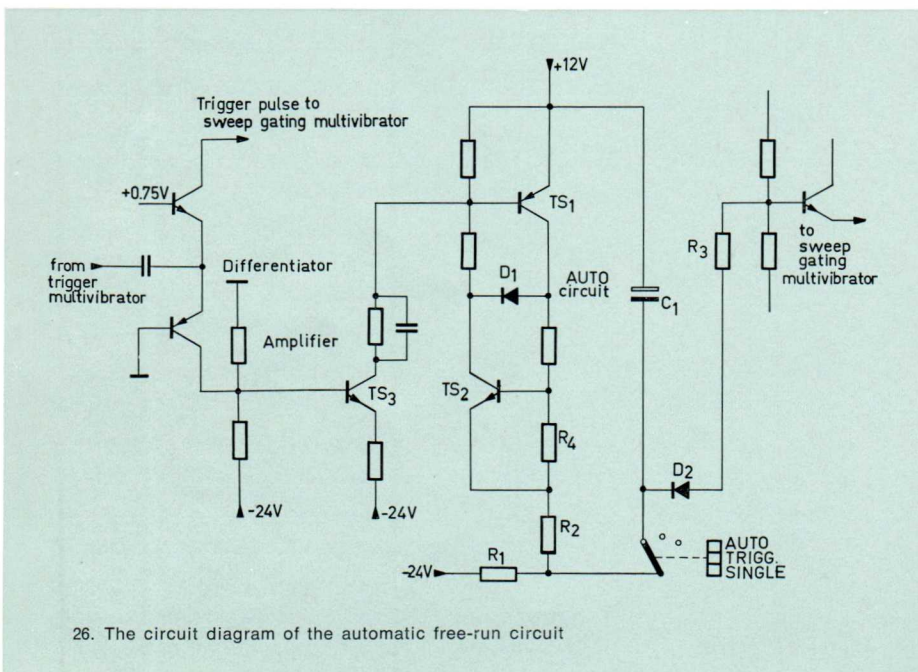

26. The circuit diagram of the automatic free-run circuit

If the controls of the oscilloscope are not properly adjusted it is desirable to have an image on the screen whether there is a vertical signal or not in order to facilitate the correct adjustment.

This can be realized by putting the mode switch in position AUTO. This connects the automatic free-run circuit to the time-base to run free in the absence of trigger pulses. When trigger pulses with a repetition frequency of more than 2 Hz are present, the time base is automatically set for triggered operation.

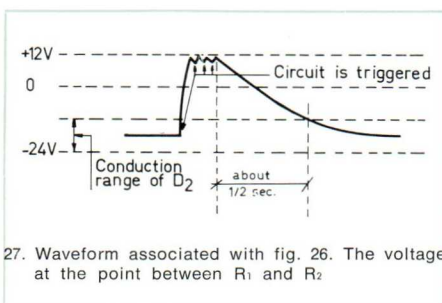

27. Waveform associated with fig. 26. The voltage at the point between R_1 and R_2

The free-run circuit consists of a monostable PNP-NPN multivibrator. In the absence of trigger pulses at the base of TS_1 (see fig. 26), TS_1 , D_1 and TS_2 are cut off. The current through R_1 is taken via D_2 and R_3 from the voltage divider which determines the input voltage of the sweep gating multivibrator (SGM); see page 18. When trigger pulses are passed via amplifier TS_3 to the base of TS_1 , the latter will conduct. The current produced in this way will give rise to a voltage drop across R_4 which will make TS_2 conducting.

The cumulative effect causes TS_1 and TS_2 to bottom rapidly; diode D_1 will then conduct. The current now flows through TS_1 , D_1 , TS_2 and R_2 ; it is derived from the tank capacitor C_1 . The current is limited by R_2 . As C_1 is discharged, the voltage at the point between R_1 and R_2 will rise to about 12 V (see fig. 27). Diode D_2 will now be cut off, which will cause the input voltage of the SGM to return to the level required for triggering. After being bottomed, both

transistors will be cut off again. If trigger pulses remain absent, the voltage between R_1 and D_2 will again reach such a level as to cause diode D_2 to conduct after about $\frac{1}{2}$ sec, and the time base will again run free. If on the other hand the automatic free-run circuit receives a trigger pulse again within this $\frac{1}{2}$ sec, the tank capacitor will discharge without making D_2 conducting.



The integrator

by A. W. Goossens

A voltage increasing linearly with time (saw-tooth voltage) can be made by passing a constant current through a capacitor. Well known systems working in this way are the bootstrap and the Miller integrator. However, the PM 3250 makes use of a third method, which is simpler in principle, giving an improved operation at fast sweep speeds. The operation of the integrator is described below, with reference to fig. 28.

The constant current required for the saw-tooth voltage is obtained by feeding transistor TS_2 from a point of constant voltage (emitter of TS_1) via a selectable resistor R_2 . The collector current of TS_2 will now be independent of the collector voltage, and be determined by V_{R2}/R_2 .

The collector current of TS_2 can be varied by changing V_{R2} (by means of the continuous TIME/div control) or by changing R_2 ; the latter can be used to realize part of the step control of the TIME/div value.

In order to keep the current through TS_2 within limits throughout the whole range from 1 s/div to 50 ns/div, the capacitance C must also be varied in steps.

These limits (from about 15 μ A to about 5 mA) are determined on the low side by the leakage currents through the charger, discharger, output amplifier and capacitor, which is appreciable at higher temperatures, and on the high side by the maximum permissible power dissipated by TS_2 . The output amplifier consists of a Darlington pair (TS_4 , TS_5), whose current is kept constant during the sweep by the transistor TS_6 , connected as a current source. In order to keep the input resistance as high as possible, the current through TS_4 is made low. However, this low current means that TS_4 is not so suitable for high frequencies. This difficulty is got round by shunting TS_4 for high frequency so that high frequencies pass directly to the base of TS_5 .

The emitter of TS_5 delivers the voltage for both the Hold-off circuit and (at least with

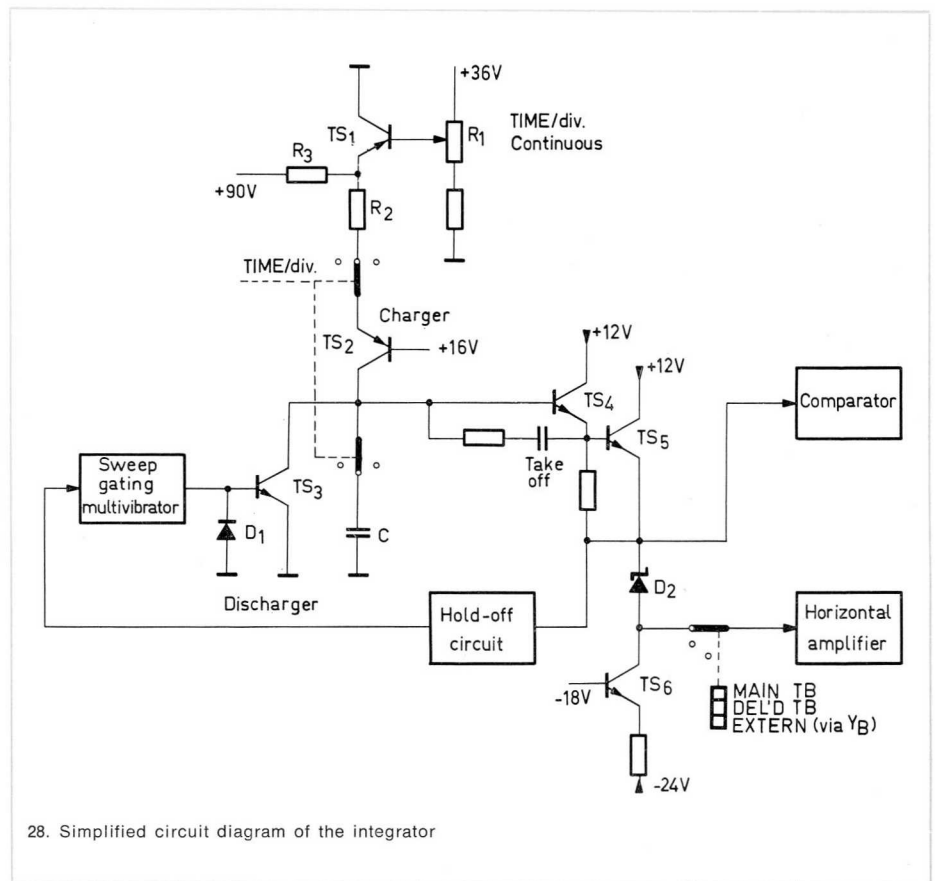

28. Simplified circuit diagram of the integrator

the main time base) for the comparator. The DC component is brought to a suitable value by means of the Zener diode D_2 , and is fed to the horizontal amplifier. When the saw-tooth voltage reaches a certain value (see page 26), the sweep gating multivibrator is switched over by means of the hold-off circuit. The sweep gating multivibrator controls the transistor TS_3 , which is used as a switch, so that the capacitor C is discharged to the right level at the right time.

The hold-off circuits

by A. W. Goossens

In order to prevent jitter, both the output voltage of the integrator and the voltage of the deflection plates must be allowed to come completely to rest after the fly-back of the time base before the next sweep of the time base starts (see page 18). This is achieved by "holding the sweep gating multivibrator off" for a short time after the completion of the time-base sweep. For the main time base, this hold-off time is realized by charging the hold-off capacitor and allowing it to discharge relatively slowly. This manner of holding off is unnecessary with the delayed time base, as the main time base already ensures that there is sufficient delay. The main and delayed hold-off circuits operate in practically the same way (see fig. 29 and 30).

Main time base set to TRIGG.

When the output voltage of the integrator reaches a certain value, determined by the resistances R_1 , R_2 and R_3 , D_1 will start to conduct. The voltage at the point joining R_1 and R_2 , and hence the emitter voltage of TS_7 , will rise. The hold-off capacitor C_1 is charged, and the hold-off multivibrator (TS_2 , TS_3) switches over. The collector of TS_2 becomes more positive, as a result of which the SGM is switched over via the emitter-follower TS_1 (see page 25). The SGM will bottom the discharger, so that the time-base capacitor is discharged. The voltage across D_1 falls, and D_1 will cut off. The base voltage of TS_7 again assumes the level determined by R_1 , R_2 and R_3 . TS_7 becomes cut off, because the hold-off capacitor must first be discharged via R_4 . As soon as the voltage across C_1 will have fallen so far that the hold-off multivibrator switches over again, the hold-off time is finished. This causes the input voltage of the SGM to assume such a level that the next trigger pulse to arrive will start the time base.

Main time base set to AUTO

This circuit works as described above for

the TRIGG setting, except that the automatic free-run circuit ensures that the time base will start "free-running" if no trigger pulses are received for $1/2$ sec or more. (see page 22).

Main time base set to SINGLE

With the mode switch at SINGLE, the base voltage of TS_7 is set at such a value (by removing R_3 from the circuit) that TS_7 starts conducting before the voltage across C_1 reaches the lower switch-over point of the hold-off multivibrator, so that this multivibrator will not be able to switch over. In order to set the hold-off multivibrator for single-sweep operation, the SET READY button is pushed in. This causes the base voltage of TS_4 to fall so far that the current which originally flowed through TS_4 now passes through D_2 . The hold-off multivibrator is thus deprived of current. When the SET READY button is released, TS_4 starts conducting again, so that TS_2 starts conducting (since $V_{BTS_2} > V_{BTS_3}$). The hold-off multivibrator is now set so that it is ready to trigger the SGM. The READY indicator indicates the position of the hold-off multivibrator, and hence whether the time base is ready to start or running.

With very low-frequency phenomena, where use is made of the lowest time-base settings (e.g. 1 to 0.1 s/div), it is often desirable to end the sweep prematurely. This can be done at any position of the mode switch by pushing in the SET READY button.

Delayed time base

The delayed time base is built as a single-sweep circuit with the reset circuit operated by the main time base (see fig. 30). The saw-tooth voltage produced by the main time base is compared in a comparator circuit with a DC voltage regulated by the DELAY TIME MULTIPLIER potentiometer. When the instantaneous value of the saw-tooth voltage at TS_{10} exceeds the DC voltage at TS_9 , the current through TS_9

will be cut off as a result of which a positive voltage jump will be produced at the base of TS_4 , via TS_8 (see fig. 30 and 31). TS_4 will now become conducting, and the reset multivibrator (TS_5 , TS_4) will switch over. The current through TS_4 is fed to the hold-off multivibrator. Since the base voltage of TS_2 is higher than that of TS_3 , TS_2 will conduct. Depending on the setting of the AFTER DELAY TIME switch, the delayed time base will either start immediately, or is ready to be triggered.

When the saw-tooth voltage from the integrator reaches its maximum value, D_1 will start conducting. The base voltage of TS_3 will rise, and the hold-off multivibrator will switch over. As a result of this, the SGM will also switch over and the time-base capacitor will be discharged. Diode D_1 will be cut off, and the base voltage of TS_3 will assume the value determined by R_1 and R_2 . This level is too high to allow TS_3 to be cut off. The hold-off multivibrator will thus have to be switched off and on again by the reset multivibrator before the time base can be started or made ready for starting again.

The main time base can also reach the final voltage value before the delayed time base. In this case, the hold-off multivibrator will be deprived of current by the reset multivibrator, and the delayed time-base sweep will be prematurely stopped.

If the delay is set to a very low value with the DELAY TIME MULTIPLIER, so that e.g. the base voltage of TS_9 is roughly equal to the quiescent voltage at the base of TS_{10} , or slightly less than this, right at the start of the main time-base sweep, the amplitude of the current pulse delivered by TS_9 will be less than normal (see fig. 32). In this case, the main gate pulse applied to the base of TS_5 is of importance. This pulse, together with the comparator pulse, now takes care of setting and resetting the circuit. This makes it possible for the DELAY TIME MULTIPLIER to be used over the full range from 0 to 10.

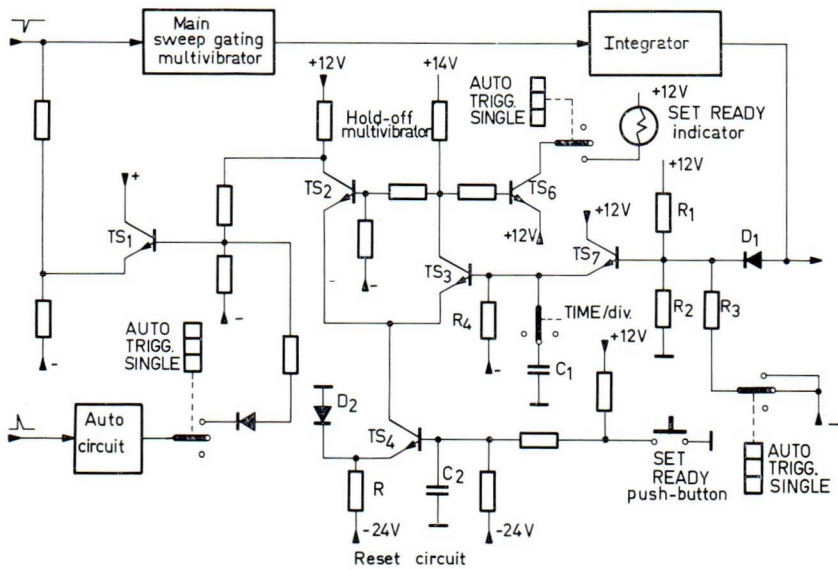

29. The simplified circuit diagram of the main hold-off circuit

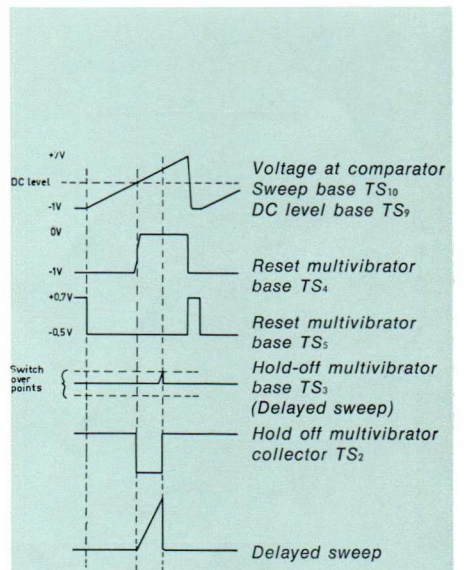

31. Waveforms related to figs 29 and 30

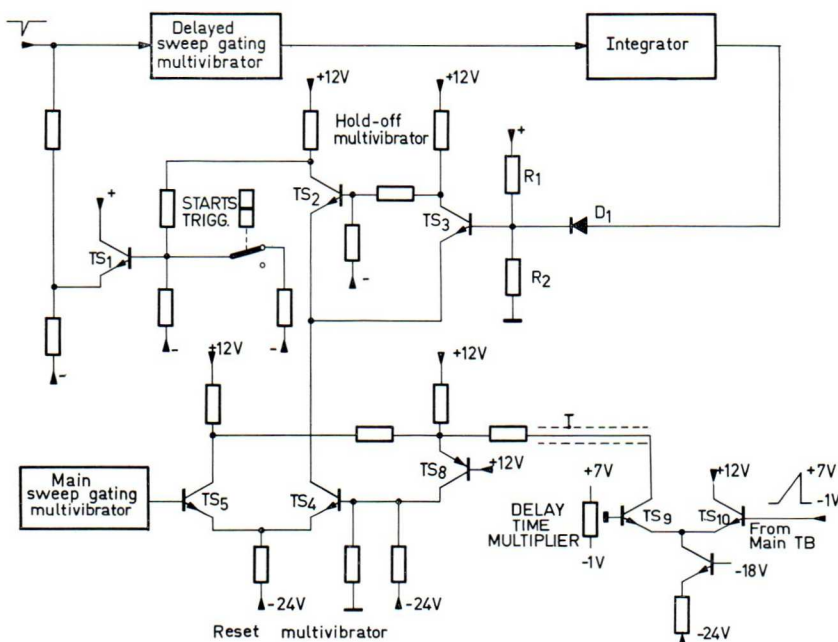

30. The simplified circuit diagram of the delayed hold-off circuit

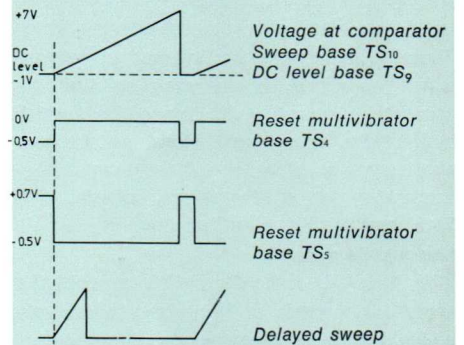

32. Waveforms when the DELAY TIME MULTIPLIER is set at zero

The horizontal amplifier

by A. W. Goossens

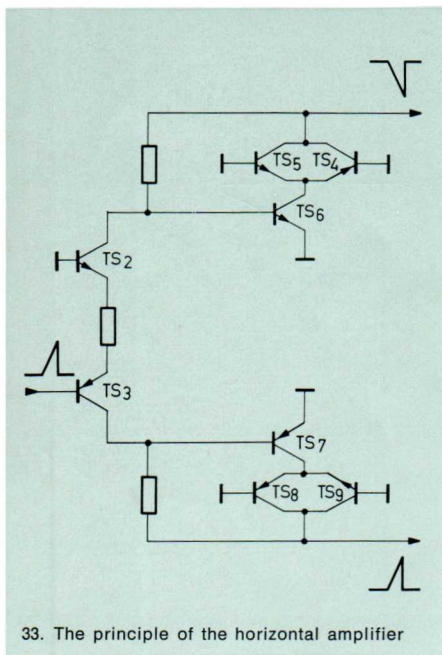

33. The principle of the horizontal amplifier

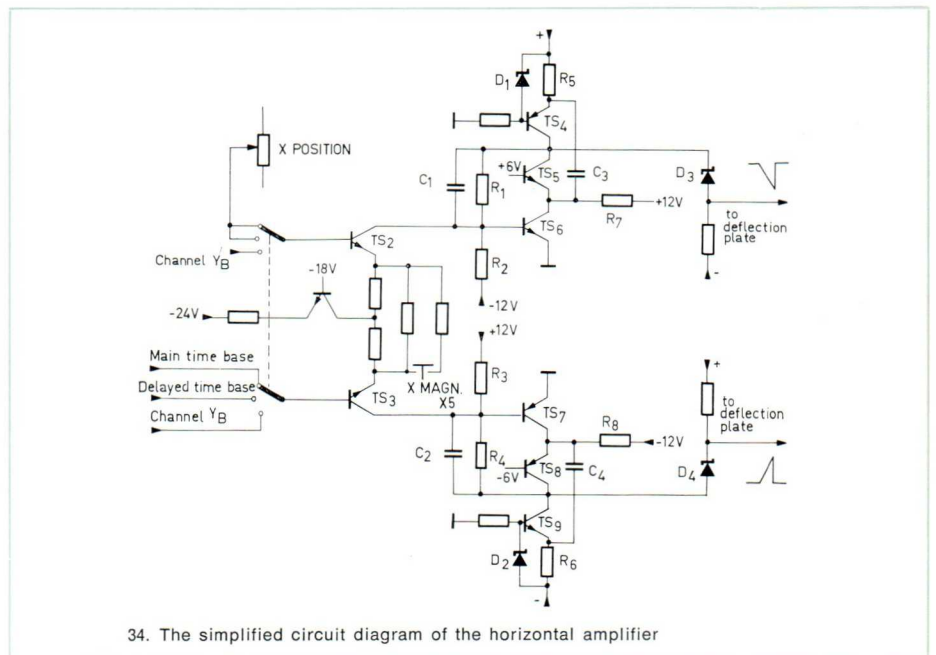

34. The simplified circuit diagram of the horizontal amplifier

The horizontal amplifier must be able to amplify not only saw-tooth voltages produced in the PM 3250 but also external voltages fed in via channel Y_B . In order to meet the exacting requirements made on linearity, accuracy and power consumption, the circuit is designed so that the currents through all transistors which might have an adverse effect on the properties in question are increasing during the linear part of the sweep voltage.

This has led to a rather unusual circuit; see fig. 33 and 34.

The X DEFL selector switch selects the signal and feeds it to a long-tailed pair, which is set so that the maximum output voltage of the output stage is not exceeded, even with the X MAGN control at x5. The output stage consists of two shunt-feedback double cascodes (see fig. 33, which shows the principle for AC). The current feedback ensures that both the input and the output impedance is low. When the amplifier is driven by saw-tooth voltages TS_6 , TS_5 , TS_7 and TS_8 are made

more conducting during the sweep, so that the current, which has to charge the deflection plates in a short time, can far exceed the quiescent current. During the flyback, TS_4 and TS_9 are conducting, so that TS_5 and TS_8 will pass less current. In order to prevent TS_6 and TS_7 from being cut off under these conditions, these transistors receive extra current via R_7 and R_8 , see fig. 34.

At very low frequencies both the sweep and the flyback are provided by the lower cascodes TS_6 , TS_5 and TS_7 , TS_8 alone, and transistors TS_4 and TS_9 are used as current sources. The voltages indicated by + and - are not stabilized.

The current through the circuit is determined to a first approximation by V_{D1}/R_5 and V_{D2}/R_6 . The current is not affected by mains fluctuations, so that both the DC setting and the amplification are kept constant once more.

In the mid-screen position, (with the trace in the middle of the screen), the collector voltages of the transistors TS_4 and TS_5 are

about + 90 V, while those of TS_8 and TS_9 are about -90 V. These voltages are brought to 0 V with the aid of D_3 and D_4 ; this corresponds to the mean deflection potential of the vertical amplifier.

The amplification, largely determined by the resistance R_1 (R_4), and the resistance between the emitters of TS_2 and TS_3 is changed when the X MAGN. control is in its x5 setting by connecting an extra resistance between these emitters.

When the amplifier is driven by e.g. sinusoidal signals via channel Y_B , the dynamic range is limited at high frequencies by the constant supply current (V_{D1}/R_5), whose magnitude is determined by the maximum allowable dissipation (transistors TS_4 , TS_5 , TS_8 , TS_9), the maximum mains voltage (nominal + 10%) and the maximum ambient temperature (45° at max. mains voltage). At 5 MHz, however, a deflection of as much as 6 div is still possible.

Z amplifier

by P. H. v.d. Laar

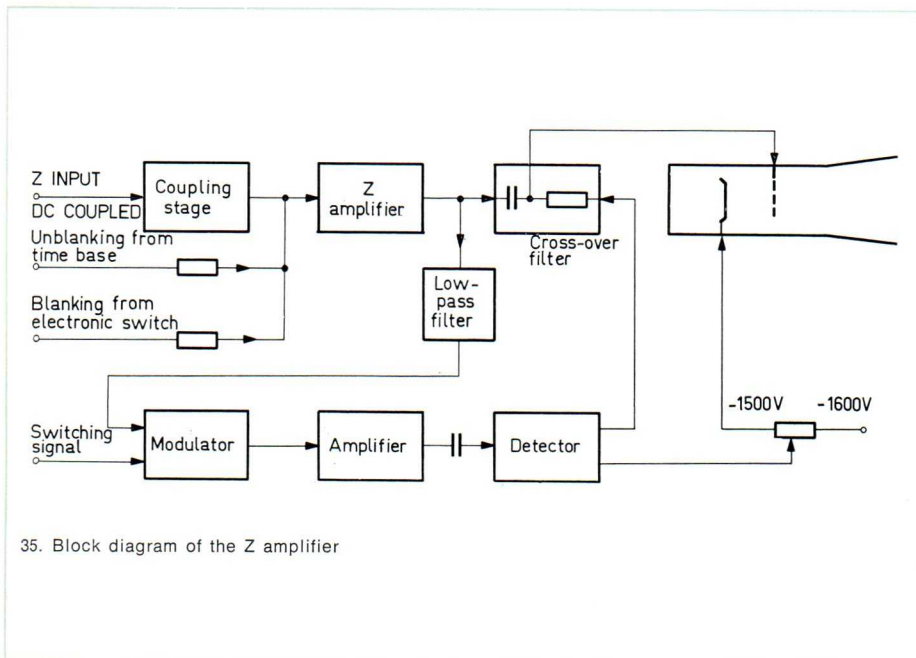

35. Block diagram of the Z amplifier

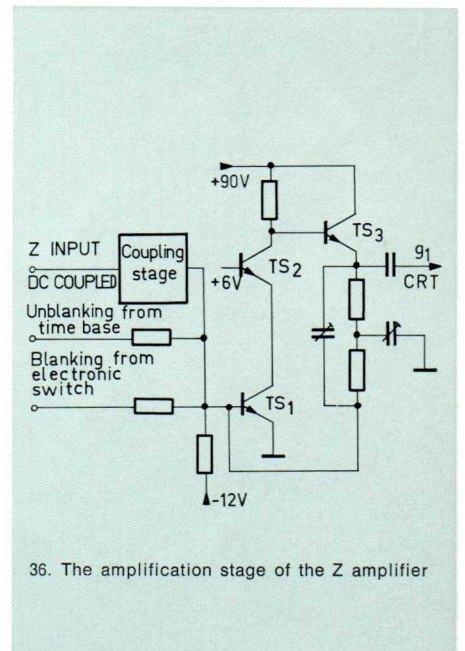

36. The amplification stage of the Z amplifier

The Z amplifier ensures that the luminance signals are applied to the control grid of the CRT with the right amplitude and potential, see fig. 35.

This stage can receive the following input signals:

- an unblanking pulse from the main time base, when the X DEFL switch is in position MAIN TB
- a combined unblanking pulse from the main and delayed time bases, if the delayed time base is switched on (see fig. 24).
- an unblanking pulse from the delayed time base, with the X DEFL switch at DEL'D TB (see fig. 23).
- an unblanking pulse during the switching edge of the pulse from the electronic switch, with the latter set to CHOPP.
- external luminance-modulation signals, which are supplied to the DC coupled Z input.

The various signals, in the form of current pulses, must be led from the time base

and the amplifier units to the Z amplifier with as little loss as possible. This is realized with the aid of cables which are terminated with their characteristic impedance at the input side of the Z amplifier. Fig. 36 shows the circuit diagram of the Z amplifier proper. This stage consists of the transistors TS₁ and TS₂ in cascode, followed by TS₃ connected as an emitter-follower. Shunt feedback is applied across the whole stage, thus making the input impedance very low. This is necessary in order to ensure that the various input signals cannot interfere with one another. The feedback is realized with a bridged T-filter, which gives optimum step response.

The output of the amplifier stage is at a low potential. The control grid of the CRT, on the other hand, is at a high negative potential, namely -1500 V. An HT coupling capacitor must therefore be placed in the lead carrying the output signal of the amplifier to the CRT.

The high-frequency components of the

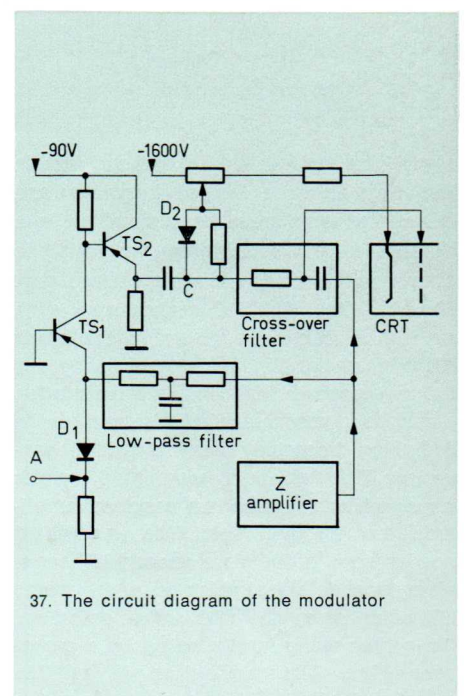

37. The circuit diagram of the modulator

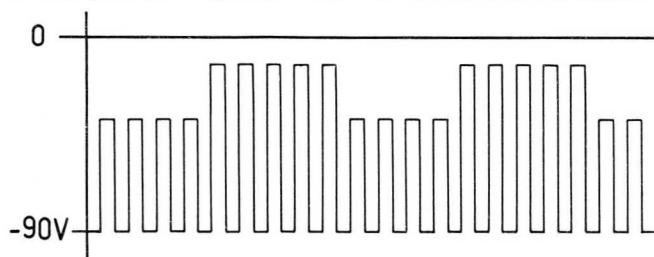

38. Waveforms produced at the collector of TS_1

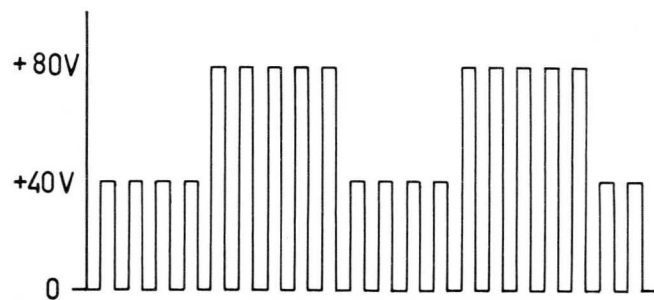

39. Waveforms of input voltage of diode D_2

amplifier and the modulator.

The modulated voltage at the collector of TS_1 is fed to an emitter-follower TS_2 . This signal is then passed via the coupling capacitor C to the detector diode D_2 , which reproduces the DC component (see fig. 39).

The detected signal is fed to a cross-over filter, where the carrier wave is suppressed, and the high-frequency and low-frequency components are mixed and applied to the control grid of the CRT.

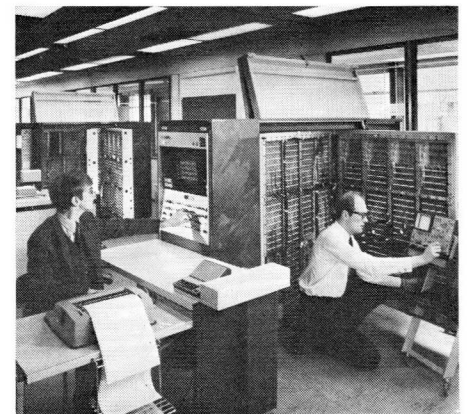

signal can be transmitted without loss in this way; however, the low-frequency and DC components must be transmitted in a different way. A floating voltage supply is often used to bridge this big voltage gap. However, the PM 3250 makes use of a modern solution, as shown in the block diagram of fig. 25. The low-frequency and DC components are fed as modulation signal to a modulator, which receives its switching frequency from the EHT converter. This gives a modulated carrier wave, which is given the required amplitude by an amplifier. The modulated carrier wave is fed via a second HT capacitor to a detector which is at the same HT potential as the CRT. After detection, the carrier wave is eliminated by a cross-over filter. The modulation is suitable mixed with the HF components from the

Z amplifier, and the resulting signal applied to the control grid of the CRT.

The modulator

The circuit diagram of the modulator is shown in fig. 37. The switching signal is applied to point A. This signal makes diode D_1 periodically cut-off and conducting. When D_1 is cut off, the transistor TS_1 conducts and conversely, when the diode is conducting the transistor is cut off. The signal applied to A thus controls the passage of the signal current from the Z amplifier through TS_1 . A square-wave voltage, whose amplitude depends on the signal current, is thus produced at the collector of TS_1 (see fig. 38).

In order to prevent the signal current from interfering with the switching voltage, a low-pass filter is placed between the Z

Cathode-ray tube

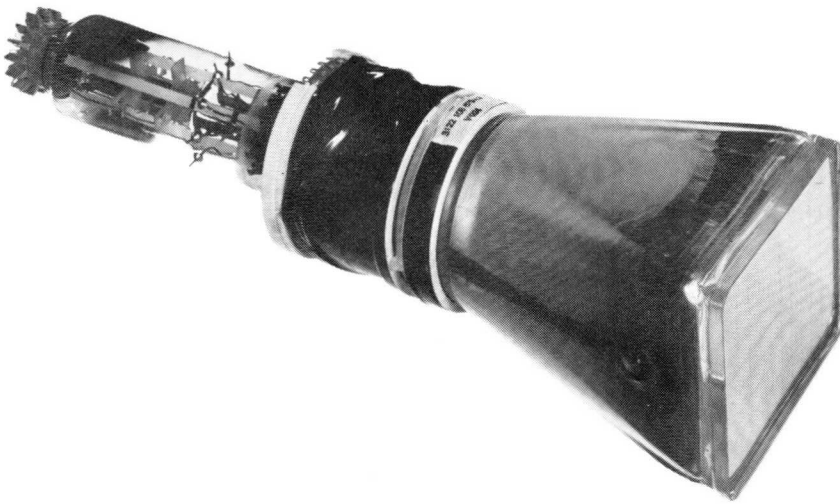

40. The cathode-ray tube used in the PM 3250 oscilloscope

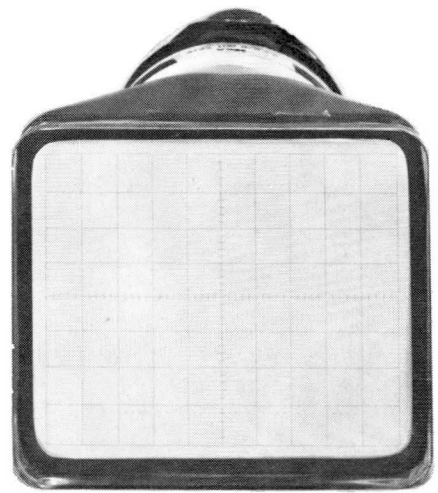

41. The graticule of CRT

The type used is the Philips D14 - 160 GH/09, see figs 40 and 41 a 14-cm (diagonal) rectangular flat-faced oscilloscope tube with mesh and a metal-backed screen.

The tube is provided with an internal graticule with an area of 100 x 80 mm², the illumination of which is continuously variable. In order to facilitate rise-time measurements, broken lines are provided 10% below the top and 10% above the bottom of the graticule.

The tube is used with a total accelerator voltage of 10 kV. With the other tube voltages at their optimum value, the trace width is only 0.35 mm at a beam current of 10 μ A.

In order to align the X deflection with the horizontal axis of the internal graticule, the whole picture can be rotated by means of a rotation coil inside the mu-metal screen surrounding the tube.

The angle between the two deflection directions in the tube can be adjusted to 90° exactly with the aid of a second correction-coil system.

Calibration generator

by F. Govaerts

The repetition frequency of the square-wave voltage is determined by the coupling capacitor C_1 and the total collector impedance R_c of TS_1 . This can be shown as follows:

If e.g. TS_1 is conducting then TS_2 is cut off, and the current through TS_1 is equal to the sum of the currents through TS_3 and TS_4 .

$E_c = R_c (I_3 + I_4)$. When TS_2 becomes conducting, this voltage is applied across C_1 , so we have now:

$$C V = I t$$

$$C R_c (I_3 + I_4) = I_4 t \text{ where } t = \frac{R_c C (I_3 + I_4)}{I_4}$$

The same relation is found when TS_1 becomes conducting. Now if $I_3 = I_4$, then $t = 2 RC$; $T = 2t$, because of the symmetry of the square-wave voltage, so

$$f = \frac{1}{T} = \frac{1}{4 R_c C}$$

The frequency and the output voltage can be adjusted by means of R_1 and R_2 respectively.

In order to stabilize the frequency of the circuit against temperature fluctuations, a copper resistor is taken for R_3 . The positive temperature coefficient of resistor R_3 then balances the negative temperature coefficient of the other frequency-determining components.

In order to keep the output voltage constant, R_4 (an NTC resistor) is used to compensate the variation of V_{be} of TS_3 and TS_4 , and the temperature coefficient of the components of the current sources.

Thanks to these measures, both the output voltage and the frequency of the calibration generator are accurate to within 1%.

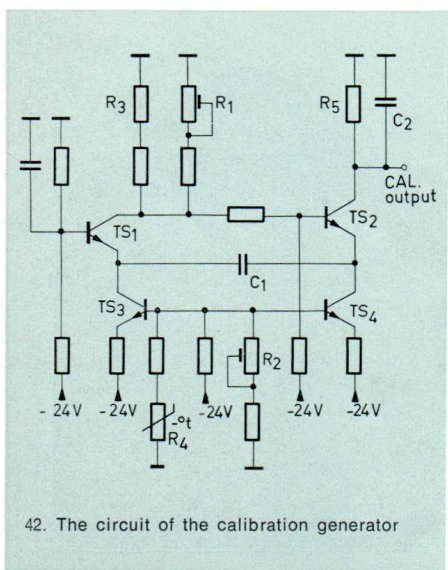

The calibration voltage of the PM 3250 is produced by an emitter-coupled multi-vibrator (transistors TS_1 and TS_2) see the figure 42.

The emitter resistors of TS_1 and TS_2 are formed by the transistors TS_3 and TS_4 , connected as current sources and adjusted to give equal currents. As a result, the output voltage is symmetrical, and the repetition frequency of the square-wave voltage is independent of the current setting. The output voltage is determined by the product of R_5 and the sum of the currents through TS_3 and TS_4 .

42. The circuit of the calibration generator



Mechanical construction

by J. Bethlehem, H. A. Janssen and
P. W. M. Poels

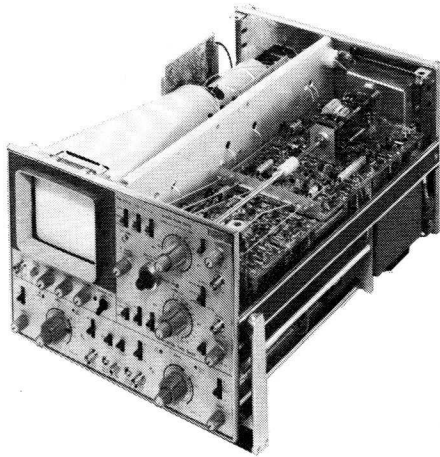

43. The instrument without covers

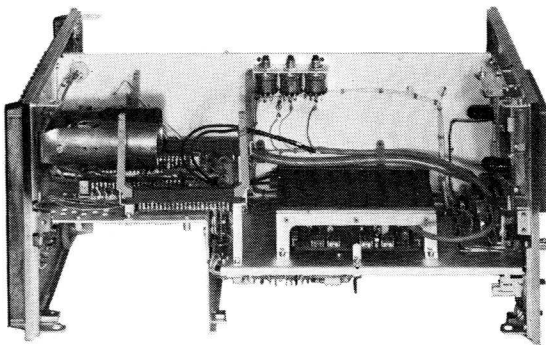

44. The frame

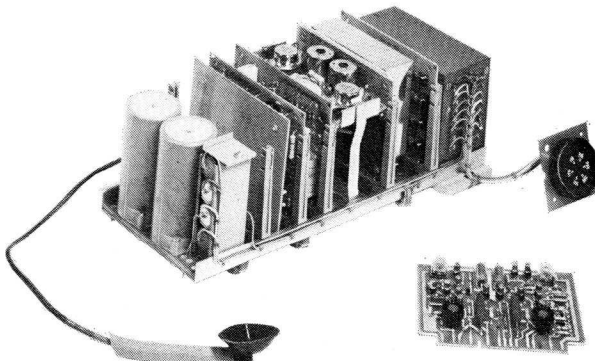

45. The power supply unit

Construction of the instrument

The housing of the PM 3250 is chosen so as to ensure optimum strength and serviceability (see fig. 43 and 44).

The frame of the apparatus consists of a front and rear wall of diecast aluminium, connected by partitions and straight profiles.

The front wall has a number of supporting points for the various sub-units into which the apparatus is divided. The text plate is also fixed on to the front wall.

The rear wall serves as a heat sink. Thanks to this, use of a cooling fan has proved unnecessary. The rear wall is also provided with two ridges on which the apparatus can rest if it is placed on the back side.

The above-mentioned combination of walls, partitions and profiles forms a very stable and rigid structure in itself; this is the backbone of the oscilloscope. The various electrical units are mounted in this frame; each unit is designed as a self-contained whole, as far as possible, and the various units are connected by cables with plugs. This layout improves the serviceability considerably.

The use of printed-circuit boards with printed edge connectors represents another step in the same direction. The hull of the apparatus consists of two separate hoods; both being fixed in place with snap fastenings, so that they can be removed quickly.

Perforations are avoided in the cap, to stop dust and dirt from getting into the instrument. The perforations as there are in the cabinet are fully in accordance with the safety regulations of the IEC.

Structure of the subunits

POWER-SUPPLY (see fig. 45)

The power supply is constructed as a rigid self-contained unit, which can be removed as a whole from the apparatus.

Two profiled steel carriers form the backbone of this subunit. A printed matrix and a number of connector blocks are fixed on these carriers. The printed boards (with plug-and-socket connections) of which the power-supply unit is built up are slid into these connector blocks. The last are provided with nylon keys so that only the right printed board can be inserted into a given connector block. This greatly improves the serviceability of the unit.

TIME BASE (see fig. 46)

The time base has been constructed on the same basic principle. This whole subunit, with its 2 printed boards, can also be completely removed from the instrument. All connections with other subunits are realized by cables with plugs, which can easily be removed. The time-base unit derives its mechanical rigidity from a diecast aluminium frame, on which the printed boards and rotary switches are mounted. The front of this frame bears a

plate on which all the time-base controls are mounted. Measurements can be carried out even when this unit is removed from the oscilloscope.

THE VERTICAL ATTENUATOR AND PRE-AMPLIFIER UNIT

This unit contains the high ohmic input attenuator, and the pre-amplifier, fig. 47. The sensitivity control (from 2 mV/div to 20 V/div in steps of 1—2—5) is realized with the aid of a rotor. This rotor carries nine RC networks which give attenuations of 1000—500—250 times etc. corresponding to the various settings from 20 V/div to 50 mV/div.

For the more sensitive settings there is no input attenuation, see page 7.

The compact construction means that the signal path can be kept short. The system

is screened, so that the high sensitivity cannot be disturbed by external effects. Both the rotor and the circuit boards with components mounted on it can be changed, independently of one another.

This unit forms a functional whole, with the AC-O-DC switch, continuous vertical sensitivity control, gain and DC-balance controls; it can simply be removed from the apparatus as a whole, and replaced. The other part of the vertical amplifier is situated near the two attenuator units, so that the signal leads can be kept as short as possible, thus reducing interference, fig. 48. The circuit board of this amplifier is fixed underneath the horizontal middle partition.

SUSPENSION OF THE CRT

The CRT is provided with an elastic sus-

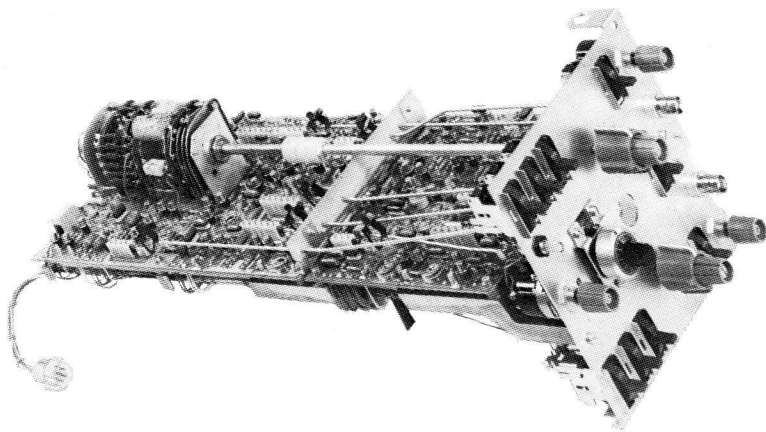

46. The time base unit

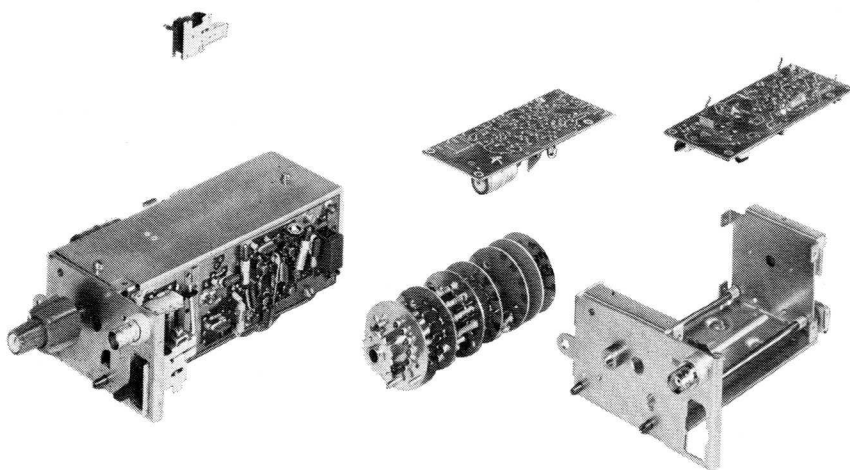

47. The attenuator and pre-amplifier

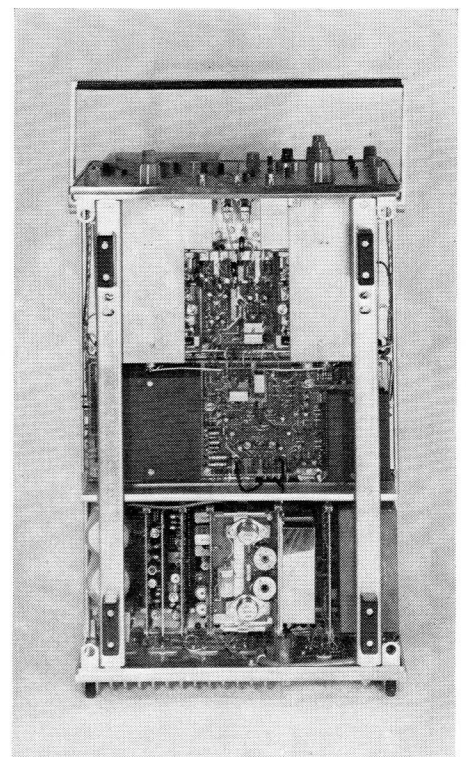

48. The vertical amplifier

pension. The front of the CRT is enclosed in horizontal direction between two sheets of plastic material and in the vertical direction between two adjustable springs. The plastic sheets have a double function: to assist in the illumination of the internal graticule and to act as shock-absorbers for lateral forces. The rear end of the CRT is mounted in a holder with a rubber collar. The CRT is screened by means of a mu-metal tube which is in contact with the cast-aluminium front wall, and at the back rests on an insulated support on the tube holder, which is fixed to the rear wall by means of two screws.

The PM 9350 probe

by P. W. M. Poels and G. P. H. Oltuis

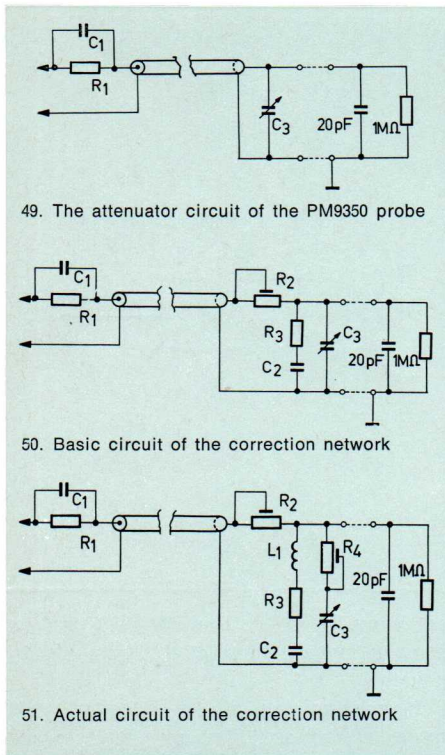

The PM 9350 is a new passive attenuating probe, developed for oscilloscopes with a bandwidth of up to about 50 MHz (eg. the PM 3250) and an input capacitance of between 14 and 21 pF in parallel with 1 Mohm.

Three parts may be distinguished in the electrical circuit of the probe:

1. The attenuation network

In order to make the capacitive load on the circuit under measurement as low as possible, voltage division in the ratio of 10 : 1 is used. The total capacitance of the oscilloscope input, correction network and cable is about 80 pF.

With a capacitance nine times less than this in the tip of the probe, attenuated signal transmission which is frequency-independent at low frequencies is possible, fig. 49.

2. The cable

Ohmic losses in the cable, together with the capacitances present, form a low-pass filter, which is apparently undesirable. In practice, however, it is found that these losses are beneficial to damp the reflections in the — not properly matched — cable, thus reducing unacceptable transient effects with pulses of rise times less than 15 ns.

If the inner conductor of the cable is given an ohmic resistance of about 250 ohm/m, a good compromise is obtained between the rise time of the pulse and the transient effects.

3. The correction network

At frequencies above 25 MHz, the cable begins to behave as a long line. It will therefore be necessary to provide the cable with a matched load, as nearly as possible, in order to prevent reflections. As a result of the ohmic losses in the cable, the matching is not so critical. The matched load is only of importance at high frequencies; the load resistance can thus be earthed via a small capacitance. The low-frequency voltage division is adjusted with C_3 . The potentiometer R_2 and

the resistor R_3 together form the matched load for the cable. The high-frequency voltage division is made equal to the low-frequency division with the aid of R_2 . In principle, this gives the following probe circuit, see fig. 50.

For practical reasons, the coil L_1 and the potentiometer R_4 also have to be included in the circuit, see fig. 51.

L_1 improves the step response for very short rise times, while sagging of the pulse top can be corrected with the aid of R_4 . The intrinsic rise time of the PM 9350 probe is better than 2.4 ns, and the deviations in the amplitude transfer amount to less than 3%.

4. The mechanical construction

In the mechanical design, care has been taken to ensure that the probe is handy and easily accessible into compact circuits. The nose of the probe is slim. The middle part can be rotated about the long axis, so that the probe can be handled without exerting torsion on the cable. The form of the probe has been chosen so that it can be used, both with and without the measuring hook.

The probe consists of the measuring pin with cable and correction network, and the following auxiliary parts, see fig. 52.

- A. one measuring hook; this can be fitted over the measuring pin, and hooked on to the circuit at the point of interest.
- B. one earthing lead with alligator clip.
- C. one springy earthing pin, for tests with a short earthing path.
- D. two insulating caps.
- E. one BNC probe adaptor.
- F. two miniature connectors (these are particularly recommended for HF measurements and routine measurements at fixed points).

Specifications

Attenuation: 10 : 1

Input resistance: 10 Mohm

Input capacitance: 9.1 pF

Rise time (of probe only): 2.4 ns

Max. input voltage: 500 V

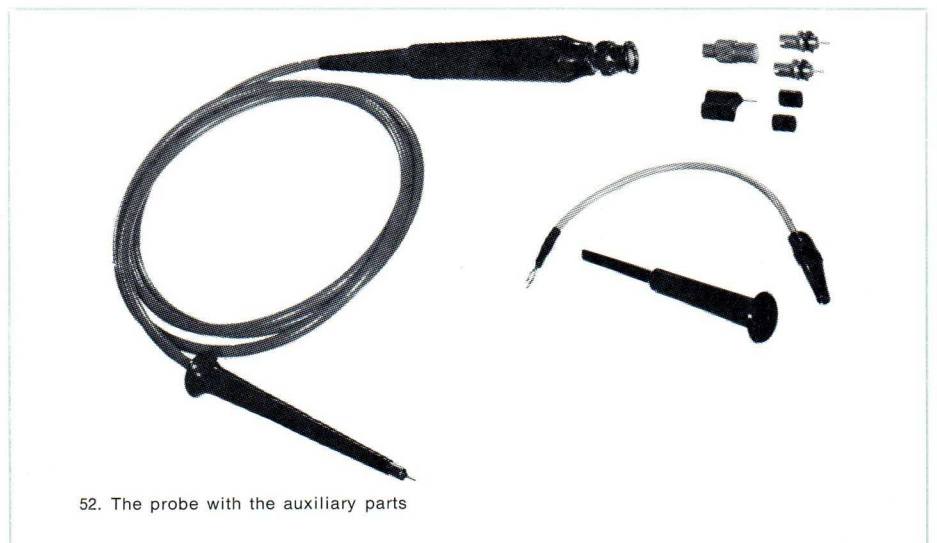

The measurement of relatively small signals with the aid of the PM 3250

by H. B. Mors and W. G. M. Spapens

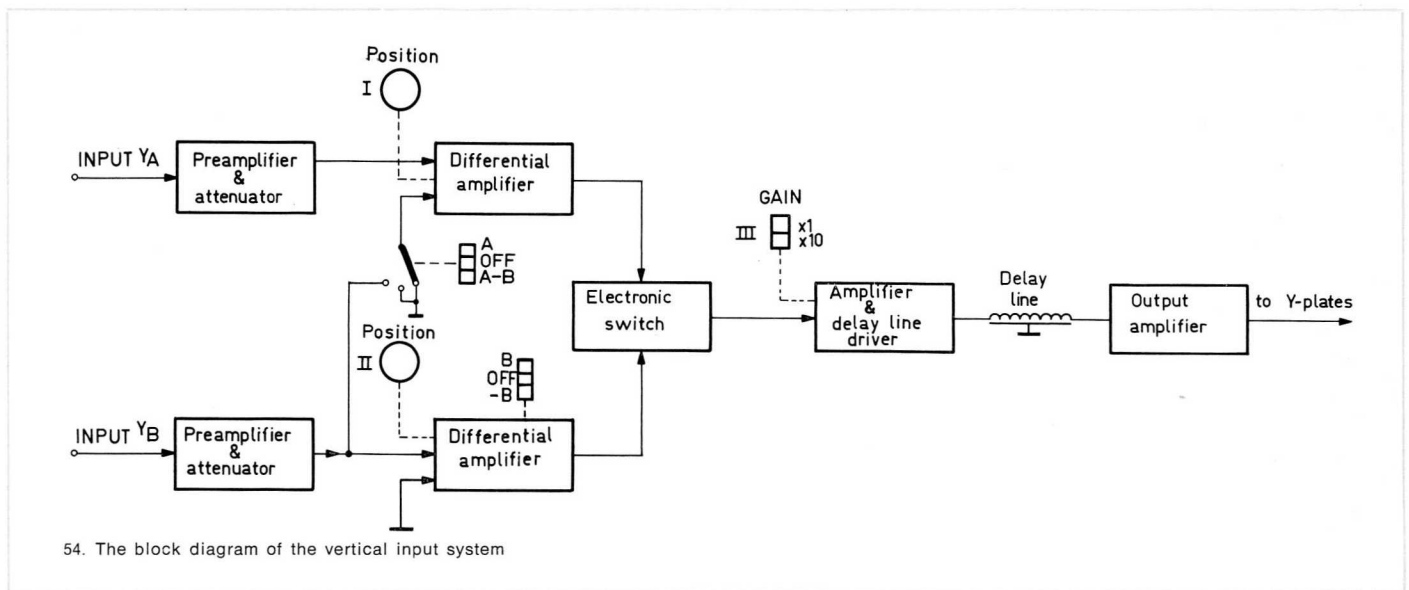

In most cases, the smallest signal which can be measured with an oscilloscope depends on the maximum sensitivity of the instrument. For the PM 3250, this means that signals up to 50 MHz can be measured with a sensitivity of 2 mV/div while up to 5 MHz the extreme sensitivity of 200 μ V/div can be used.

Sometimes, however, measurements must be carried out on a small signal which forms part of a total signal of much greater amplitude; this often gives rise to special problems. If we have e.g. a signal

of the form shown in fig. 53, the oscilloscope could be set to a higher sensitivity for observation of the small signal superimposed on the big one. However, a point would soon be reached where the dynamic range of the amplifier was exceeded. Depending on the quality of the amplifier, the signal on the screen will be more or less distorted in this case.

Moreover, it may often happen that the position control can no longer bring the required detail on to the screen at extreme amplifications. There are two differ-

ent ways in which the PM 3250 can be used to make signals of this type visible, namely:

- I) by making use of the extended (x10) range of the amplifier, and the coupled extended range of the position control;
- II) by means of the differential measuring method (with selector switch set to A—B).*

* In this setting, a differential triggering signal (i.e. A—B) can be used by setting the trigger mode switch at Y_A . This can be very useful if the detail we are interested in has a different frequency from the total signal.

53. Waveform of signal small detail which is to be examined

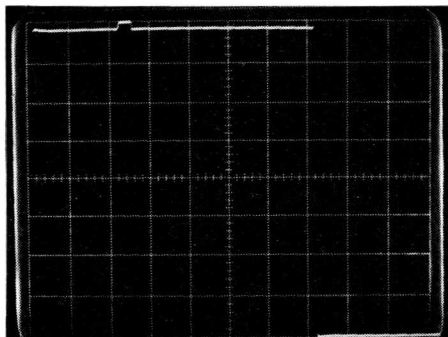

55. Waveform of detail of fig. 53 at max sensitivity (without x10 gain)

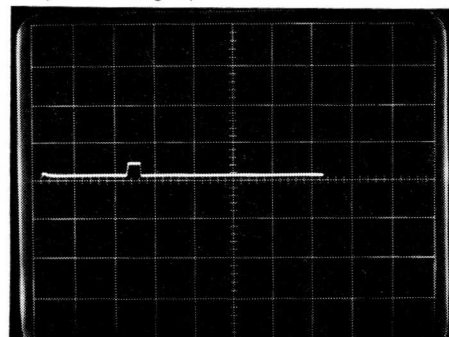

56. Waveform of detail of fig. 53 at max sensitivity with x10 gain

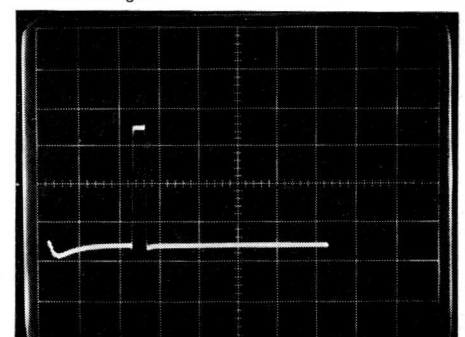

present at both points. The signal present at both points (V_1) is called the common-mode signal V_2 is called the differential mode (DM) signal. The object of differential measurement is to amplify the DM signal and suppress the CM signal.

The principle of operation of a differential amplifier can be described as follows (see fig. 57).

In the circuit of fig. 57, R_{c1} and R_{c2} are equal; R is the common emitter resistor. V_{o1} and V_{o2} are the output voltages.

The DM signal is present between inputs I and II, while the CM signal is applied between both these inputs and earth.

We shall now consider the effects of the CM and DM signals on the amplifier separately:

If the amplitude of the CM signal increases at a given moment, the current through R , and through both transistors, will increase; V_{re} will follow the CM signal. In other words, R provides negative feedback for the CM signal.

When the DM signal causes the base voltages of TS_1 to increase compared with the base voltage of TS_2 , the current through TS_1 will increase, leading to an increase in the voltage across R ; the current through TS_2 will now decrease, however. The result will be that V_{o1} is made more negative by as much as V_{o2} is made more positive. The amplification of the DM signal is not reduced by the presence of R as is that of the CM signal. The difference in amplifications is thus determined by the value of R : the larger this resistance, the greater the difference in amplification.

In order to make the value of R large while retaining the optimum operating current, this resistance is realized in practice by a transistor connected as a constant current source.

No differential amplifier will be able to suppress the CM signal completely; and, moreover it will produce a unwanted DM signal from this because the two halves of the circuit are never completely identical. The output signal of the amplifier and the image on the screen will thus always contain a component due to the CM signal, since after all the CRT is not an ideal differential amplifier either.

The frequency will also play an important role. At high frequencies, the suppression of the CM signal also depends on all the parasitic effects influencing the circuit.

The quality of a differential amplifier depends on the extent to which it suppresses the CM signal. The common-mode rejection ratio (CMR ratio) is therefore used as a figure of merit; this is defined as the ratio of the CM signal and the DM signal which must be applied to the input to give the same deflection on the screen. The CMR ratio of the PM 3250 at various frequencies is as follows:

Frequency	CMR ratio
50 Hz	> 400
100 kHz	400
1 MHz	200
20 MHz	20

For the PM 3250 this value is 40 divisions in x 1 setting of GAIN switch. This value is independent of POSITION controls settings.

Thanks to its unique method of switching (fig. 54), the PM 3250 can display on its screen the A—B signal and the $\pm B$ signal simultaneously. This can be particularly useful for measurements on digital systems. This method of switching also makes it possible to carry out XY measurements with A—B displayed vertically and B or —B displayed horizontally. Some applications of this facility are described on page 36.

I) In most oscilloscopes, the position control makes it possible to display on the screen any desired detail of a signal of amplitude equal to three times the screen height. The PM 3250 has a screen height of 8 divisions; this means that it must be possible to shift the signal 8 divisions upwards or downwards, so that both the top and bottom of the larger signal can be shown on the screen. The positioning signal thus corresponds to more than 16 divisions.

This positioning signal is applied to point I and II (see fig. 54).

Now since the x1—x10 switch which controls the amplification factor is placed after the position controls (at point III), the positioning signal for both channels is also multiplied by a factor of 10, to more than 160 divisions. This means that any desired detail of a signal with an amplitude exceeding 160 divisions can be brought on to the screen. In fig. 53, the total signal amplitude is 0.8 V, while the detail signal is only 15 mV (0.15 div; sensitivity 0.1 V/div.) In the x1 setting, the sensitivity can be increased to 50 mV/div, which will cause the detail signal to extend over 0.3 div (fig. 55). The amplification cannot be increased further, because at 20 mV/div the total signal amplitude would be 40 divisions, so that the detail signal could not be brought on to the screen.

If now the x1—x10 switch is set at x10 with the sensitivity control at 50 mV/div, the actual sensitivity will be 5 mV/div. The amplitude of the total signal now becomes 160 divisions, and that of the detail signal 3 divisions (see fig. 56).

The extended positioning range (>160 div) now allows the detail signal (or any other point of the total signal) to be brought within the graticule.

II) If it is desired to make differential measurements, the detail signal V_2 of interest must be present as a voltage difference between two points, while the signal on which V_2 is superimposed is

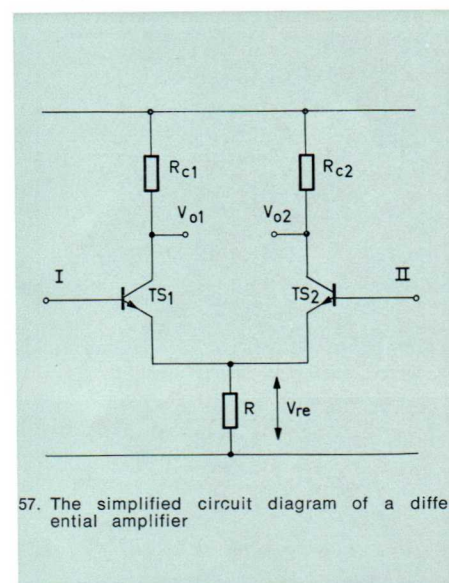

57. The simplified circuit diagram of a differential amplifier

The display of A-B and B or -B

by H. B. Mors and W. G. M. Spapens

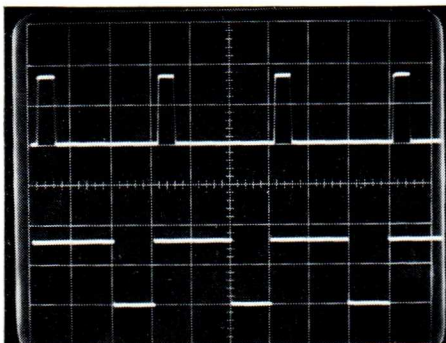

58. Signals applied to channel A and B

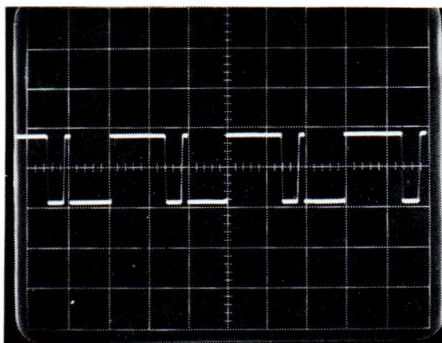

59. The difference signal A-B

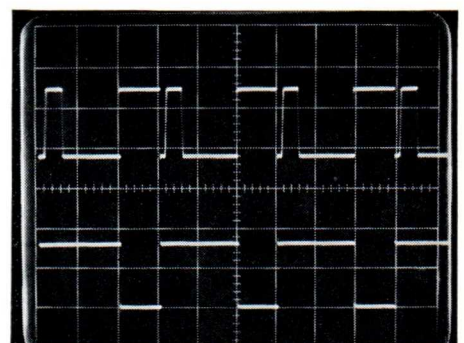

60. A-B together with the signal in channel B

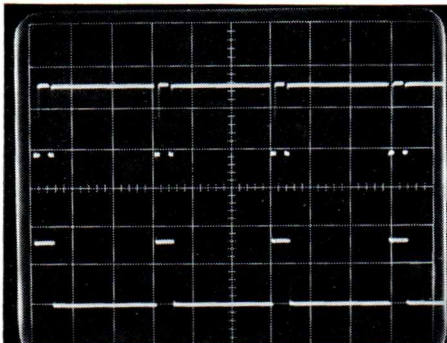

61. A-B signal changed due to change in B signal

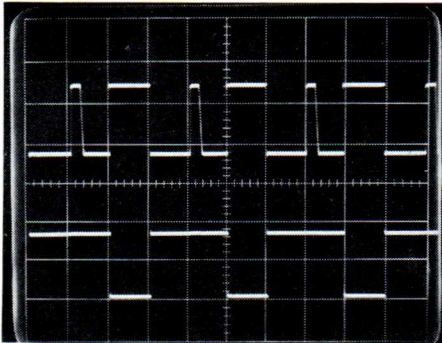

62. A-B signal changed due to change in A signal

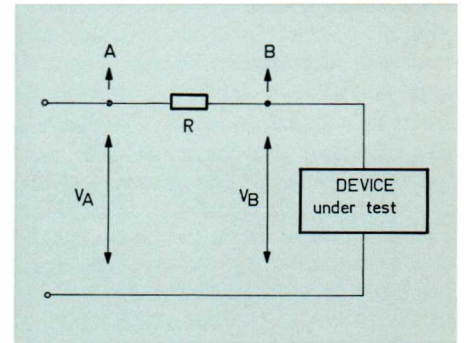

63. Principal of set-up for display of characteristic of active device

Thanks to the way in which it carries out differential measurements, the PM 3250 can display the B or -B signal on its screen at the same time as the A-B signal (see fig. 54).

In other types of oscilloscopes, the differential signal is realized by adding the signal from channel A on to the inverted signal from channel B by opening both gates of the electronic switch. With such a system, the total amplitude range which can be dealt with will be smaller; this range will also depend on the setting of the position controls, since the positioning signal is applied to the signal line before the electronic switch. This means that if maximum positioning signals of opposite signs are applied to the two channels, the trace will be in the middle of the screen - but the range within which linear response is obtained is now severely limited

Forming the differential signal before the position control, and hence before the electronic switch, has the following advantages:

1. Deflection range and linearity independent of position;
2. Larger deflection range for CM signals;
3. Possibility of simultaneous display of A-B and B or -B;
4. Possibility of displaying A-B vertically and B or -B horizontally.

The possibility of displaying A-B and B or -B simultaneously simplifies measurements of signals in the A-B mode, since the input signals can now be checked without switching over to ALT or CHOPPED. The signal which is to be checked for possible changes is now fed to the B channel; it is hence always possible to know whether changes in A-B are due to changes in A or in B. (see figures 58 up

to 62).

As may be seen from fig. 2, the above-mentioned facility can also be used for X-Y measurements, so that A-B can be displayed vertically and B horizontally. In view of the placing of the x1-x10 switch in the circuit, the maximum vertical sensitivity is 200 μ V/div, while the maximum horizontal sensitivity is 2 mV/div. This unique XY facility can be used to measure the current-voltage characteristic of active components or circuits as shown in fig. 63. See also figs. 64 to 67.

The display of V_B horizontally represents the voltage across the device in question, while $V_A - V_B$ represents the current through the device. (multiplied by a constant factor R).

If an AC voltage is taken for V_A , the current-voltage characteristic of the device under test will be displayed on the screen.

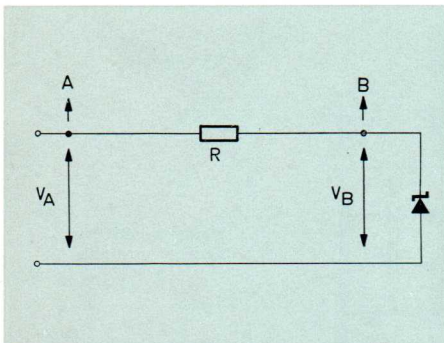

64. Set up for determination of the characteristic of a zener diode

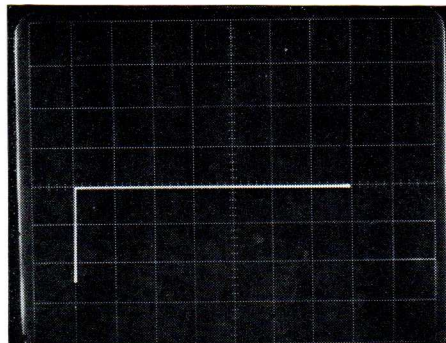

65. Oscillogram of zener characteristic

1. Determination of the characteristic of a Zener diode

In this circuit,

- $R = 100 \text{ ohm}$
- $V_A = \pm 10 \text{ V half sine wave}$
- $D = \text{BZY 67 Zener diode}$

The oscillogram (fig. 65) shows that

- $V_B = \text{Zener voltage} = 7 \text{ V};$
- Zener current = 25 mA;
- Vertical: 1 V/div = 10 mA/div
- Horizontal: 1 V/div = 10 mA/div

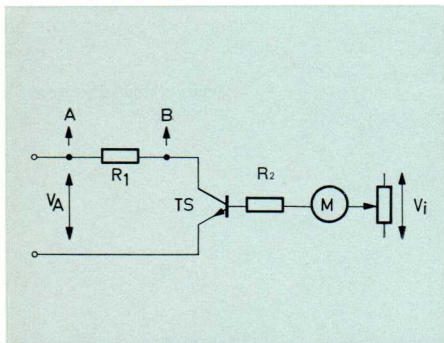

66. Set up for determination of the $I_C = f(V_{CE})$ characteristic of a transistor

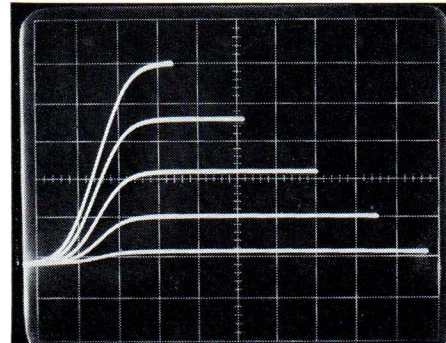

67. Multi exposure oscillogram of transistor characteristic

2. Determination of a transistor characteristic

In this circuit

- $R_1 = 1 \text{ kohm}$
- $R_2 = 100 \text{ kohm}$
- $M = \mu\text{A-meter for base current}$
- $TS = \text{BSX 21}$

$V_A = \pm 10 \text{ V half sine wave}$

$V_i = \text{adjustable DC voltage for setting } I_B$

The oscillogram of fig. 67 shows $I_C = f(V_{CE})$ with I_B as parameter.

- Curve 1 is the characteristic for $I_B = 25 \mu\text{A}$
- Curve 2 for $I_B = 50 \mu\text{A}$
- Curve 3 for $I_B = 75 \mu\text{A}$
- Curve 4 for $I_B = 100 \mu\text{A}$
- Curve 5 for $I_B = 125 \mu\text{A}$

Horizontal 1 V/div
Vertical 1 V/div = 1 mA/div

Accurate time measurements with an oscilloscope

by H. B. Mors and W. G. M. Spapens

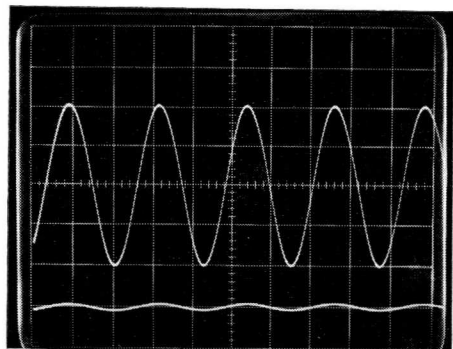

68. When angle between signal and horizontal graticule line is high (upper trace) more accurate measurements can be made than when this angle is low (lower trace)

Oscilloscopes are often used at present for accurate time measurements. The error of such measurements is usually taken as the tolerance of the time base, the reading error generally being neglected. However, this latter error can have a very great influence on the accuracy of the measurement.

To gain an insight into the accuracy of time measurements, we must consider the following factors.

- A. The inaccuracy of the time base.
- B. The reading error, which can be subdivided into the effects of:
 1. the line thickness,
 2. the angle between the signal and the horizontal graticule line at the point where the reading is made,
 3. parallax.

A. THE INACCURACY OF THE TIME BASE
This is generally specified for the middle 8 divisions of the deflection. A tolerance of about 3% is common for professional equipment.

B. THE READING ERROR
This is determined by the quality of the CRT spot, which depends in its turn on whether focussing is optimum, and on the astigmatism, at a given intensity. For a good line thickness, the intensity should not be too high, as a high intensity

has an adverse effect on the optimum results which can be obtained.

It will be obvious that a small angle between the trace on the CRT screen and the horizontal line of the measuring graticule will reduce the accuracy of the reading; see fig. 68.

It is therefore advisable to work with the biggest possible display and if possible to take the reading at the steepest part of the trace.

If a CRT with an external graticule is used, this gives rise to an extra reading error due to parallax, see fig. 69.

The parallax error is due to the fact that the graticule and the screen are not coplanar; this error is avoided by use of a CRT with an internal graticule.

We shall now consider a number of ex-

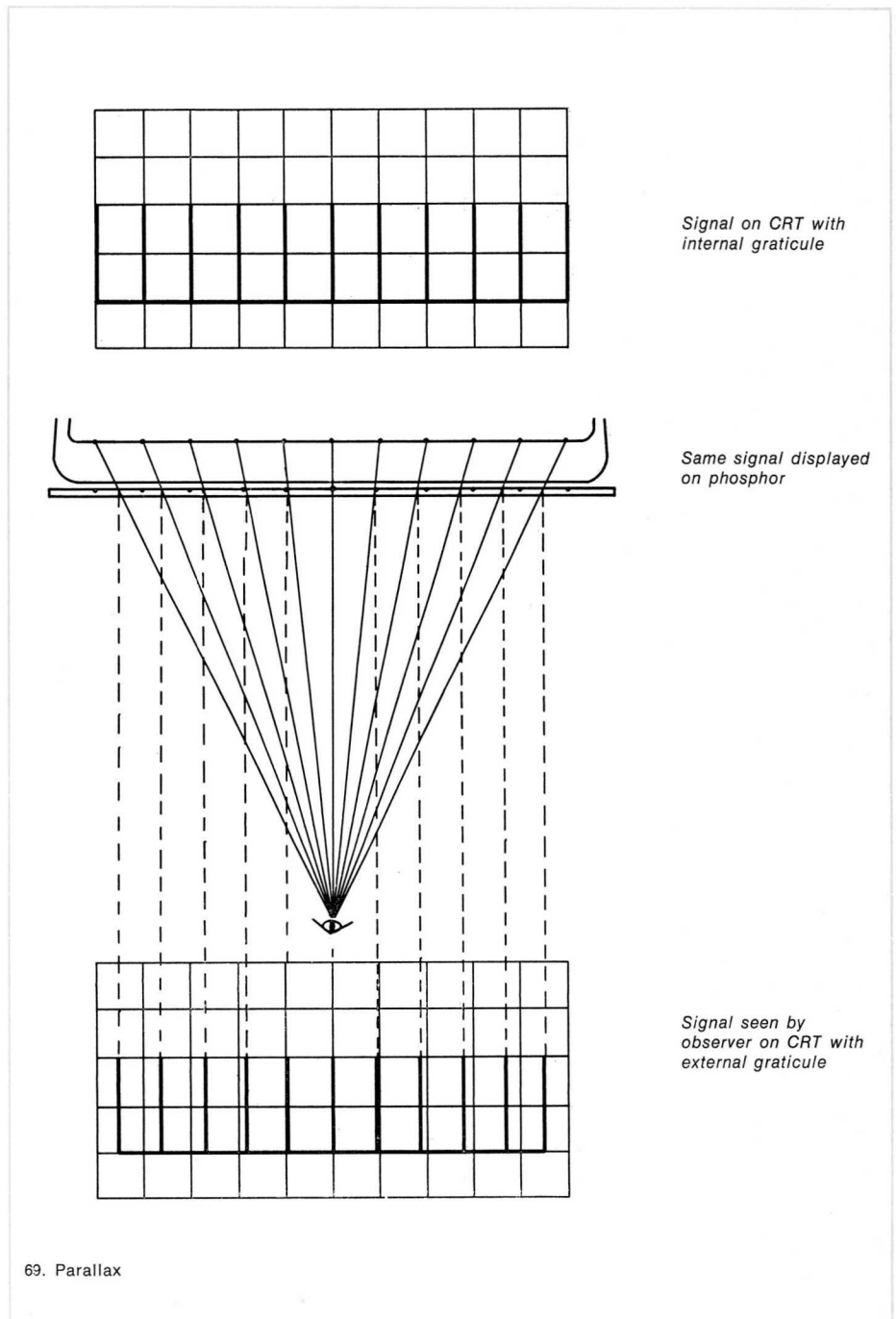



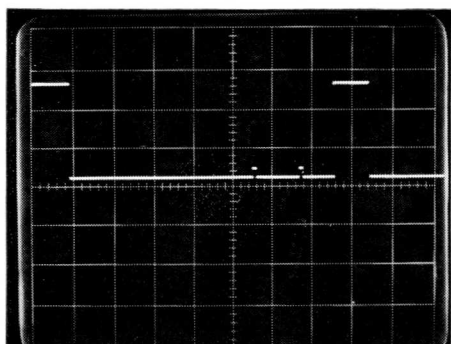

70. Complete waveform to be examined

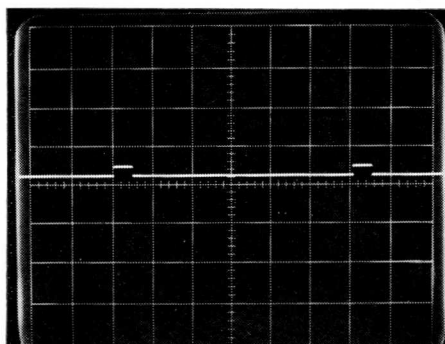

71. Display of detail of fig. 72 with x5 magn.

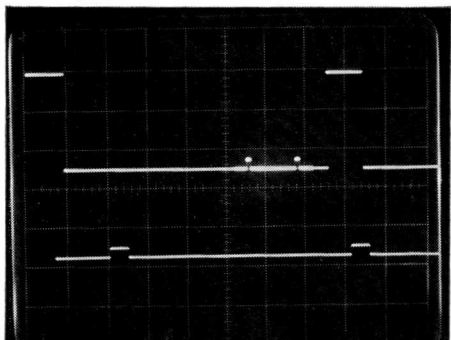

72. Display of detail of fig. 70 with the delayed time base method 2 a

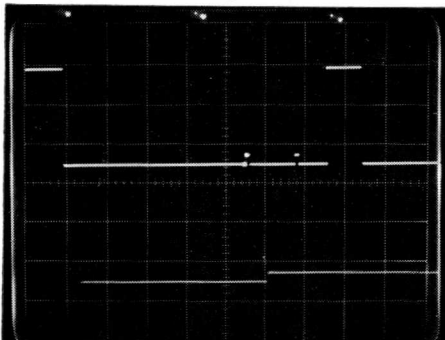

73. Display of detail of fig. 70 with the delayed time base, method 2b

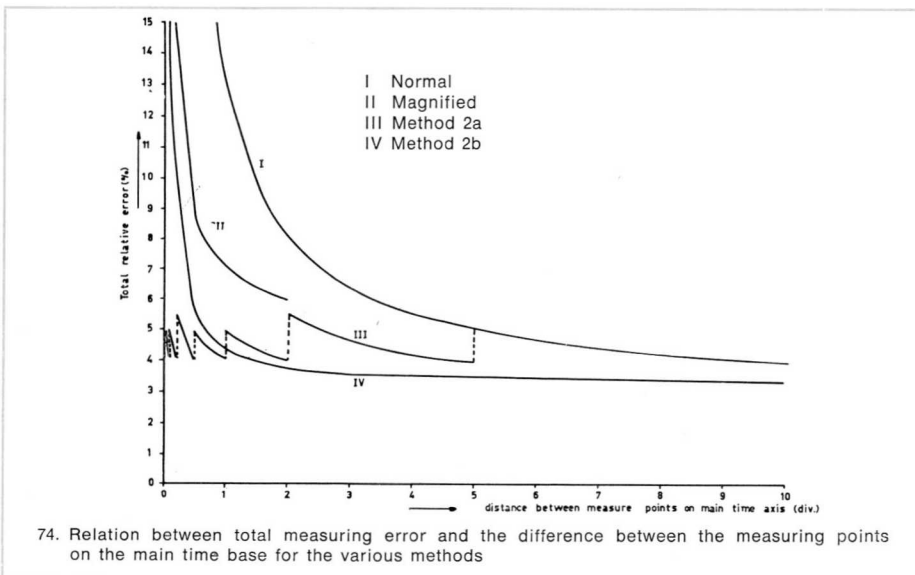

74. Relation between total measuring error and the difference between the measuring points on the main time base for the various methods

amples, to clarify the influence of the above-mentioned factors on the result of the measurements. We will also indicate which measuring method can be used to obtain the most accurate results.

For the purposes of our considerations we assume that the maximum inaccuracy of the time base is 3%, and that the CRT has an internal graticule, so that parallax is avoided. We shall take the reading error to be $\pm 1/20$ division.

We assume further that the measurements are made with the signal of fig. 70.

The time-base speed is $20 \mu\text{s}/\text{div}$.

The distance between the two large pulses is 7.6 div.

Period = $7.6 \times 20 \mu\text{s} = 252 \mu\text{s}$.

Relative error

$$= \text{TB inaccuracy} + \frac{2 \times \text{reading error}}{\text{measured value}} \times 100\%$$

$$= 3\% + \frac{2 \times 0.05}{7.6} \times 100\% = 4.3\%$$

The distance between the two small pulses is 1.2 div.

The error of this value is thus

$$3\% + \frac{2 \times 0.05}{1.2} \times 100\% = 11.3\%$$

It will be clear that as the distance between the two points in question is reduced, the relative influence of the reading error will increase, this can lead to very large errors in the measured result.

We must thus reduce the effect of the reading error by making the distance between the two points in question a large as possible.

One solution which is sometimes applicable is to trigger on the first small pulse and to increase the time-base speed, but this cannot be done generally with signals like the one of our example.

There are two methods which can lead to better results, viz:

1. The use of a horizontal magnifier
2. The use of a second time base

1. The distance between the two points can be increased by a calibrated magnifier.

In this case, however, it should be realized that the time-base inaccuracy is higher when a magnifier is used. We may take a value of 5% for this; see fig. 71.

The distance now becomes 6.0 divisions. The relative error will hence be

$$5\% + \frac{2 \times 0.05}{6.0} \times 100\% = 5 + 1.67 = 6.67\%$$

2. The most accurate results can be obtained with the aid of a second time base. There are two possible methods of measuring accurately a time interval like that shown in fig. 70 in this way:

a. With the aid of the main time base, the delayed time base is started shortly before the appearance of the first pulse. The speed of the second time base can now be chosen such that the distance between the two small pulses is as large as possible (see fig. 72).

The distance between the points in question = 6.15 divisions.

Inaccuracy of delayed time base = 3%

Totaal relative error =

$$3\% + \frac{2 \times 0.05}{6.15} \times 100\% = 4.63\%$$

b. The delayed time base can be triggered near the first pulse in the same way as in method 2a; but the speed of the delayed time base is now chosen so that the distance between the two points in question is e.g. 120 divisions.

The reference point on the first pulse is now brought on a vertical graticule line by means of the delay-time multiplier, and the reading of the latter is noted. Now the corresponding point of the second pulse is brought on the same line by means of the delay-time multiplier, and the reading noted again, see fig. 73.

If the two readings of the delay-time multiplier were e.g. 6.75 and 5.52, the time interval to be measured is given by (6.75—5.52) x speed of main time base.

The total relative error is now given by: inaccuracy of main time base + relative reading error + inaccuracy of delay-time multiplier + interpolation error of delay-time multiplier.

Inaccuracy of main time base = 3%

Relative reading error on screen

$$\frac{2 \times 0.05}{123} \times 100\% = 0.08\%$$

Inaccuracy of delay-time multiplier is 0.02%

Reading error of delay-time multiplier is ± 0.5 division, which corresponds to a relative error of $\frac{2 \times 0.05}{123} \times 100\% = 0.81\%$

Total relative error =

$$3 + 0.08 + 0.2 + 0.81 = 4.09\%$$

It will be seen from the above that method 2b can give the best results.

In fig. 74, the measuring error is plotted against the difference (in divisions) between the points in question on the main time base, for the various methods.

It will be seen that a 5x magnifier can give quite a considerable improvement at short distances, but that the results are still not very accurate.

With method 2a changing over to higher sweep speeds the error can be kept very low, down to very small distances on the main time base.

Method 2b gives the most accurate results, but at very small distances the error becomes very large again, because of the reading error of the delay-time multiplier. It will be clear from the above that very large errors can be made in time measurements, and that careful consideration should be given to the choice of the optimum method if accurate results are to be obtained.

Some other Philips publications

Philips Technical Review

A monthly publication dealing with technical problems, processes and investigations on lighting, electronics, X-rays and other technical subjects, published in 3 languages viz. English, German and Dutch (subscription rate per volume Dfl. 24,—)

Contents vol 30, 1969, no. 2

Automatic drawing of masks for integrated circuits
The polytypism of silicon carbide
Monitoring for the control-rod operation of the nuclear reactor at Dodewaard
A two-stage compressor with rolling diaphragm seals

Contents vol 30, 1969, no. 3

A step-and-repeat camera for making photomasks for integrated circuits
The use of digital circuits in data transmission
Stoichiometry, I. Existence region

Contents vol 30, 1969, no. 4

Crystal growth and chemical synthesis under hydrothermal conditions
Prospecting with neutrons
Stoichiometry, II. Point defects and the control of their concentrations

Philips Research Reports

A bimonthly publication in the English language containing physical, chemical and technical papers relating to the theoretical and experimental research work carried out in the various Philips laboratories (subscription rate per volume Dfl. 45,—)

Contents vol 24, no 1

Semiconducting properties of lanthanum-cobalt oxide
Preparation and stability of enhancement n-channel MOS transistors with high electron mobility
Approximate calculations on the spreading resistance in multi-emitter structures
On the behaviour of the base-collector junction of a transistor at high collector current densities
Two new methods for determining the collector series resistance in bipolar transistors with lightly doped collectors

Contents vol 24, no 2

Automated crystal-structure determination by Patterson search using a known part of the molecule
Optical lattice vibrations and dielectric constant of tetragonal lead monoxide
Energy transfer in oxidic phosphors
A polynomial approach to linear codes

Philips Telecommunication Review

A quarterly journal in English dedicated to broadcasting, radio communication, radio relay, television, radar, switching and transmission in telephony and telegraphy, data processing and convergence.

Contents; vol 28, no 2, May 1969

300 kW short wave transmitter type FB 010
Automatic transmission measuring equipment for international telephone lines
Attenuation peaks on open wire lines and the advantages of using phantom circuit

Electronic Applications

A quarterly publication in English contains articles of interest to industry about recent developments in electronic circuits and techniques, components, materials and their applications (subscription rate per volume Dfl. 15,—)

Contents, vol 29, no 1, 1969

Recent developments in circuit and transistors for television receivers, IX E.H.T. generation from the line flyback pulse
An operational amplifier with differential FET input
Improved speed control for a permanent magnet motor

All enquires regarding subscription and correspondence should be addressed to your bookseller or to N.V. Uitgeversmaatschappij CENTREX (Centrex Publishing Co.), Nieuwe Emmasingel 9, P.O. Box 76, Eindhoven (the Netherlands).

Philips in Science and Industry

A quarterly publication in English and German containing articles on new developments and applications of products and systems for industry and research.

Contents, vol 15, no. 3

New design concepts simplify oscilloscope operation
Analog recorders
The oscilloscript high-speed recorder
Light-beam oscilloscope (Ultraviolet recorders)
Measuring chains for non-electrical parameters
Operating principle and properties of potentiometric recorders
Display and measurement with oscilloscopes
Permissible source resistance in use of self-balancing compensators

Displaying and measuring signals with maximum time resolution

Philips Welding Reporter

A quarterly publication in English and French gives technical information of general interest about welding technology and its application in the metalworking industry.

Contents, 1969/3

The welding of clad steel
Determination of the pitting susceptibility of stainless steels
From milk to milk-powder
Exhausting of welding fumes

Sound and image

A bimonthly publication in English, French, Spanish and Dutch devoted to the uses and applications of Philips industrial and professional projection, sound and television equipment.

Contents, no. 27

Three young ladies
Television keeps the ships moving
Traffic problems on both sides of the Atlantic Ocean... and Amsterdam, too, has its traffic defile
Advanced television system enhances teaching effectiveness



PHILIPS

sales and service all over the world

Algérie S.A.D.I.M.E.T., 7, Rue Docteur Trabut, Alger; tel. 647 200/1/2

Argentina Philips Argentina S.A., Casillo Correo 3479, Buenos Aires; tel. T.E. 70, 7741 al 7749

Australia Philips Electrical Ind. (Pty) Ltd., Philips House, 69-79 Clarence Street, Box 2703 G.P.O. Sydney; tel.: 20-223

België-Belgique M.B.L.E., Philips' Bedrijfsapparaat 80, Rue des deux Gares, Brussel, tel. 230000

Bolivia Philips Sudamericana, Casilla 1609, La Paz; tel.: 5270-5664

Brazil Inbelsa, Industria Brasileira de Electricidade S.A. Rua Amador Bueno 474, Caixa Postal 3159, Sao Paulo; tel.: 93-9191

Burma U. Thong Tin, 36, Barr Street, Rangoon

Canada Philips Electronic Ind. Ltd. Electronic Equipment Division, Philips House, 116 Vanderhoof Avenue, Toronto 17, Ontario; tel.: 425-5161

Chile Philips Chilena S.A., Casilla 2687, Santiago de Chile; tel.: 35081

Colombia Philips Colombiana S.A., Communications Department, Apartado Nacional 1505, Bogota; tel.: 473-640

Costa Rica Philips de Costa Rica Ltd., Apartado Postal 4325, San José; tel.: 5670

Curaçao Philips Antillana N.V., Postbus 523, Willemstad; tel.: Curaçao 36222-35464

Danmark Philips A.S., Prags Boulevard 80, Copenhagen; tel.: Asta 2222

Deutschland (Bundesrepublik) Philips Elektronik Industrie G.m.b.H., Röntgenstrasse 22, Postfach 111, 2 Hamburg 63; tel.: 501031

Ecuador Philips Ecuador S.A., Casilla 343, Quito; tel.: 30064

Egypt Resident delegate office, P.O. Box 1687 43, Kasr Nil Street Cairo; tel.: 74933

Eire Philips Electrical (Ireland) Ltd., Newstead, Clonskeagh, Dublin 14; tel.: 976611

El Salvador Philips de El Salvador, Apartado Postal 865, San Salvador; tel.: 7441

Espana Philips Ibérica S.A.E., Avenida de America, Apartado 2065 Madrid, tel.: 2462200

Ethiopia Philips Ethiopia Ltd. (Private Ltd. Co.) Cuningham Street, P.O.B. 659, Addis Abeba; tel.: 13440

France Philips Industrie S.A., 105 Rue de Paris, 93 Bobigny (Seine); tel.: 845 28-55, 845 27-09

Ghana Philips Ghana Ltd P.O. Box M14, Accra
Great-Britain Pye Unicam Ltd., Manor Royal, Crawley (Sussex) tel. 28787

Guatemala Philips de Guatemala S.A., Apartado Postal 238, Guatemala City; tel.: 20607-08-09

Hellas Philips S.A. Hellénique, B.P. 153, Athenes; tel.: 230 476

Hong Kong Philips Hong Kong Ltd., P.O.B. 2108, Rooms 1006/1008 Prince's Building Hong Kong; tel.: 33728 23548

India Philips India Ltd., PIT/S.E. Dept. 254, Dr Annie Besant Road, P.O. Box 6598, Worli, Bombay 18, tel. 246-231; 245-144

Iran Philips Iran Ltd.: P.O. Box 1297, Teheran, tel.: 48344-68344

Iraq Philips (Iraq) W.L.L., P.O. Box 5749, South Gate Post Office, Baghdad, tel.: 98844

Island Mr. Snorri P.B. Arnar, P.O. Box 354, Reykjavik; tel.: 13369

Israel Israelecta Ltd. 12, Allenby Road, P.O. Box 1608, Haifa, Phone 526231

Italia Philips S.p.A., Casella Postale 3992, Milano; tel.: 69.94

Liban Philips Liban S.A., P.O.B. 670, Beyrouth; tel.: 232303-232458/59

Malaya Philips Singapore Ltd., P.O. Box 1358 8th Floor, International BLDG. 360, Orchard Road, Singapore; tel.: 9414

Maroc Société Anonyme Marocaine de Telecommunication 2, Rue de Bapaume Casablanca; tel.: 439-92

Mexico Philips Comercial S.A. de C.V., Apartado Postal 24328 Mexico 7 D.F.; tel.: 25-15-40

Nederland Philips Nederland N.V. Boschdijk VB. Eindhoven; tel.: 43 33 33

New Zealand Philips Electronical Industries Ltd. Professional and Industrial Division, P.O. Box 6415, 18-20 Lorne Street Wellington

Nigeria Philips (Nigeria) Ltd., Philips House, No 6 Ijora Causeway, P.O. Box 1921 Lagos, Nigeria; tel.: 56051 & 56052

Nippon Philips Products Sales Corporation of Japan, Kokusai building, 7th floor Marunouchi, Chiyoda-ku, Tokyo, tel. (216) 2441

Norge Norks A.S. Philips, Postboks 5040, Oslo; tel.: 463890

Oesterreich Philips G.m.b.H., Abt. Industrie Tries terstr. 64, 1101 Wien X; 64 55 11

Pakistan Philips Electrical Co. of Pakistan Ltd Bunder Road, P.O.B. 7101, Karachi; tel.: 70071

Paraguay Philips del Paraguay S.A., Casilla de Correo 605, Asuncion; tel.: 8045-5536-6666

Peru Philips Peruana S.A., Apartado Postal 1841, Lima; tel.: 34620-40265

Philippines Electronic Development and Application Centre, 2246 Pasong Tamo Street P.O. Box 911 911 Makati Commercial Centre Makati Rizal D-708

Portugal Philips Portuguesa S.A.R.L., Rua Joaquim Antonio d'Aguiar 66, Lisboa; tel.: 683121/9

Rhodesia Philips Rhodesian (Private) Ltd., P.O. Box 994, Gordon Avenue, Salisbury; tel.: 29081

Schweiz-Suisse-Svizzera Philips A.G., Binzstrasse 18, 8027 Zürich 3, tel.: 051 44 22 11

South Africa South African Philips (Pty) Ltd., P.O.B. 7703, 2, Herbstreet, New Doornfontein Johannesburg; tel.: 24-0531

Suomi Oy Philips Ab., Postbox 10255, Helsinki 10 tel.: 10915

Sudan Geltatly Hankey & Co. (Engineering) Ltd., P.O. Box 150, Khartoum; tel.: 71183

Sverige Svenska A.B. Philips, Fack, Stockholm 27; tel.: 08/635000

Syrië Philips Moyen Orient S.A. P.O. Box 2442, Damas; tel.: 18605-21650

Taiwan Yung Kang Trading Co. Ltd., 6 Nan King East Road, 1 Section, P.O. Box 1467, Taipei; tel.: 43540

Thailand Philips Thailand Ltd., 283, Silom Road, Bangkok; tel.: 36985-8

Tunisie: Société Tunisienne d'Industrie Electronique et de Télévision, 32 bis, Rue Ben Ghedhem, Tunis

Türkey Türk Philips Ticaret A.S., Posta Kutusu 504 Istanbul; tel.: 447486

Uruguay Philips del Uruguay, Avda Uruguay 1287 Montevideo; tel.: 956 41-2-3-4

U.S.A., Philips Electronic Instruments, EMA Sales Department, 750 South Fulton Avenue, Mount Vernon, New York 10550, tel.: (914) 664-4500

Venezuela C.A. Philips Venezolana, Apartado Postal 1167, Caracas, tel.: 72 01 51

Zambia Philips Electrical Ltd., P.O. Box 553 Kitwe