

Specification MOA/CV 5466 Issue 1. Dated 3.10.1961. To be read in conjunction with K1006 (Note 9)	<u>SECURITY</u>	
	<u>Specification</u>	<u>Valve</u>
	Unclassified	Unclassified

<u>TYPE OF VALVE</u> : Pulse thyatron, hydrogen, tetrode connection with reservoir, low jitter. <u>CATHODE</u> : Unipotential. Indirectly heated. Connected to mid point of heater. <u>ENVELOPE</u> : Glass. <u>PROTOTYPE</u> : VX.4151	<u>BASE</u>	
	Special 8 Pin	
	<u>MARKING</u>	
	K1001/4 and Serial No.	
		<u>JOINT SERVICES CATALOGUE NO.</u>
		5960 - 99 - 037-2515
		<u>DIMENSIONS</u>
		See Page 5

<u>RATING</u> (Not for inspection purposes) <small>Note</small>			
Max. Peak Anode Forward Voltage	kV	25	
Max. Peak Anode Current	A	500	
Max. Mean Anode Current	mA	500	
Pb factor	V.A.	6.25×10^9	

<u>TESTS</u>	
<u>Conditions for Test</u> :	
Ef	= 6.3 volts
Eres	= 8.0 volts
epy	= 25 kV min.
egy1	= 300V max.
egy2	= 300V max. Measured from earth.
tk	= 300 sec. max.
Ecc2	= -100V
<u>Connections</u> :	
Note 10	
<u>Pin No</u> :	1 2 3 4 5 6 7 8
<u>Electrode</u> :	G1 G2 H R K R H1 IC

Ref.	Test	Conditions		Min.	Max.
4.	Holding Period	t = 96 hours			
4.10.8	Cathode Heater Current	Note 12	If	15	22 Aac
4.10.8	Reservoir Heater Current	Eres = 8.5 Vac Note 12	Ires	2.5	3.5 Aac
-	Instantaneous Starting	epy = 18.0 kV (Min) Notes 1, 2, 11, 13		-	-
4.10.17.2	D.C. Anode Voltage	Notes 1 & 3	Ebb	-	1000 Vdc
-	Operation (1)	epy = 27.5 kV prp = 450 pps t = 30 minutes Notes 1, 4, & 8			
-	Anode Delay Time	Operation (1) Note 5 t = 30	tad	-	0.5 μ S
-	Anode Delay Time Drift	Anode Delay Time Note 6	Δ tad	-	0.05 μ S
-	Time Jitter	epy = 25 kV eg1y = 300V, eg2y = 400V (Note 13) Notes 1 & 7	tj	-	0.002 μ S
-	Operation (2)	epy = 27.5 kV prp = 450 pps t = 10 minutes Eres = 9.0 volts Notes 1, 4, 8			

NOTES

1. The tube shall be tested in the test circuit shown in the attached drawing. Tests performed at repetition rates less than the resonant repetition rate shall be made with a hold-off diode in the charging circuit. The circuit constants shall be chosen so that at epy = 25.0 kV under resonant charging conditions $di/dt = 3500a/\mu S$ (min); $i_b = 500a$ (min); $t_p = 2.0 \pm 0.2 \mu S$; $prp = 500$ pps (min).

Warning : These conditions are specified only for the purpose of determining circuit constants. The actual operating voltage and repetition rates for each test is specified in the conventional manner under the particular conditions or under the general test conditions, as the case may be.

Grid Conditions for Test :

$tp_1 = 1.5 \mu\text{S Max}$, $tp_2 = 1.5 \mu\text{S Max}$, $tgd = 0.5 \mu\text{S} - 0.9 \mu\text{S}$
 $d\text{egy}_1/dt = 1000\text{V}/\mu\text{S (max)}$, $d\text{egy}_2/dt = 1800\text{V}/\mu\text{S (max)}$, $E_{c2} = -100\text{V}$
 $Z_{g1} = 2000 \text{ ohms (min)}$, $Z_{g2} = 800 \text{ ohms (min)}$

The d.c. resistance of each of the circuits between grid 1 and cathode and between grid 2 and cathode should not exceed 5000 ohms.

2. This shall be the first test after the holding period. The tube shall operate satisfactorily on push-button starting within 3 attempts when the anode voltage (epy) is applied to the tube under test in such a manner as to rise from 0 to 18kV within 0.03 sec. (the filter in the rectifier shall be designed so that the epy reaches at least 9000V within 0.015 sec). The intervals between successive attempts to instantaneously start the tube shall not be less than 10 seconds nor more than 30 seconds. Any tube failing to start within 3 attempts will be considered a failure. A heating time of 5 minutes (max) shall be allowed before initiating this test.
3. This test shall be performed within 60 seconds after Operation (1) test.
4. The tube shall operate continuously during this test without evidence of arcbreak.
5. Anode delay time (tad) is the time interval between the point on the rising front of the grid pulse where voltage is zero and the point where anode conduction takes place.
6. During the interval between 30 sec. and 15 min. of the Anode Delay Time test, the change in anode delay time (Δt_{ad}) relative to the tad value observed on the Anode Delay Time test shall not exceed the specified value.
7. The variation in firing time (tj) shall be measured by an approved method and shall not be greater than the amount specified.
8. There shall be no evidence of anode heating during this test.
9. Copies of K1006 and Inspection Instructions for Electron Tubes (ASESA, 5/10/55) can be obtained from :-
The Secretary, TL5b, M.O.A., Castlewood House, 77/91, New Oxford St, London.W.C.1.
10. No connection shall be made to pin 8 as it is used internally for a barretter connexion.
11. Eres = 8.5 volts
12. These tests shall be carried out simultaneously, but at any other time with respect to the other tests.
(15 minutes (min) warm up time shall elapse before the measurements are carried out.
13. Measured with respect to earth.

OPERATION TEST CIRCUIT

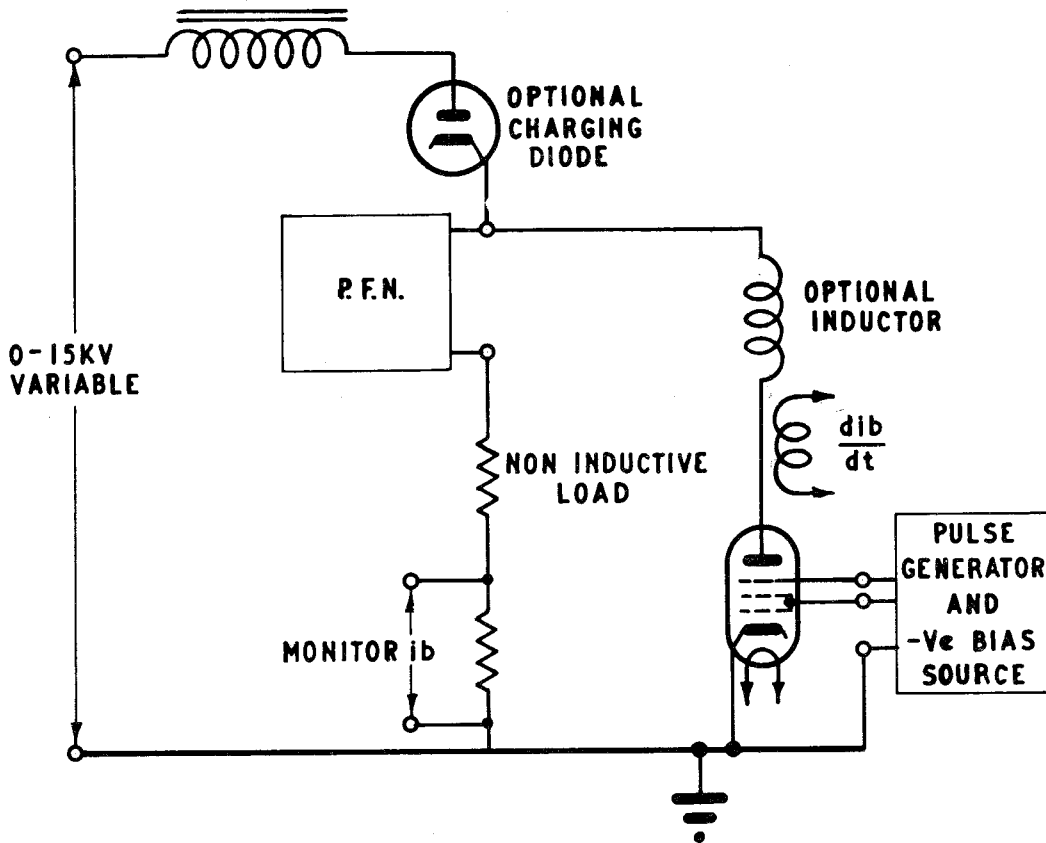

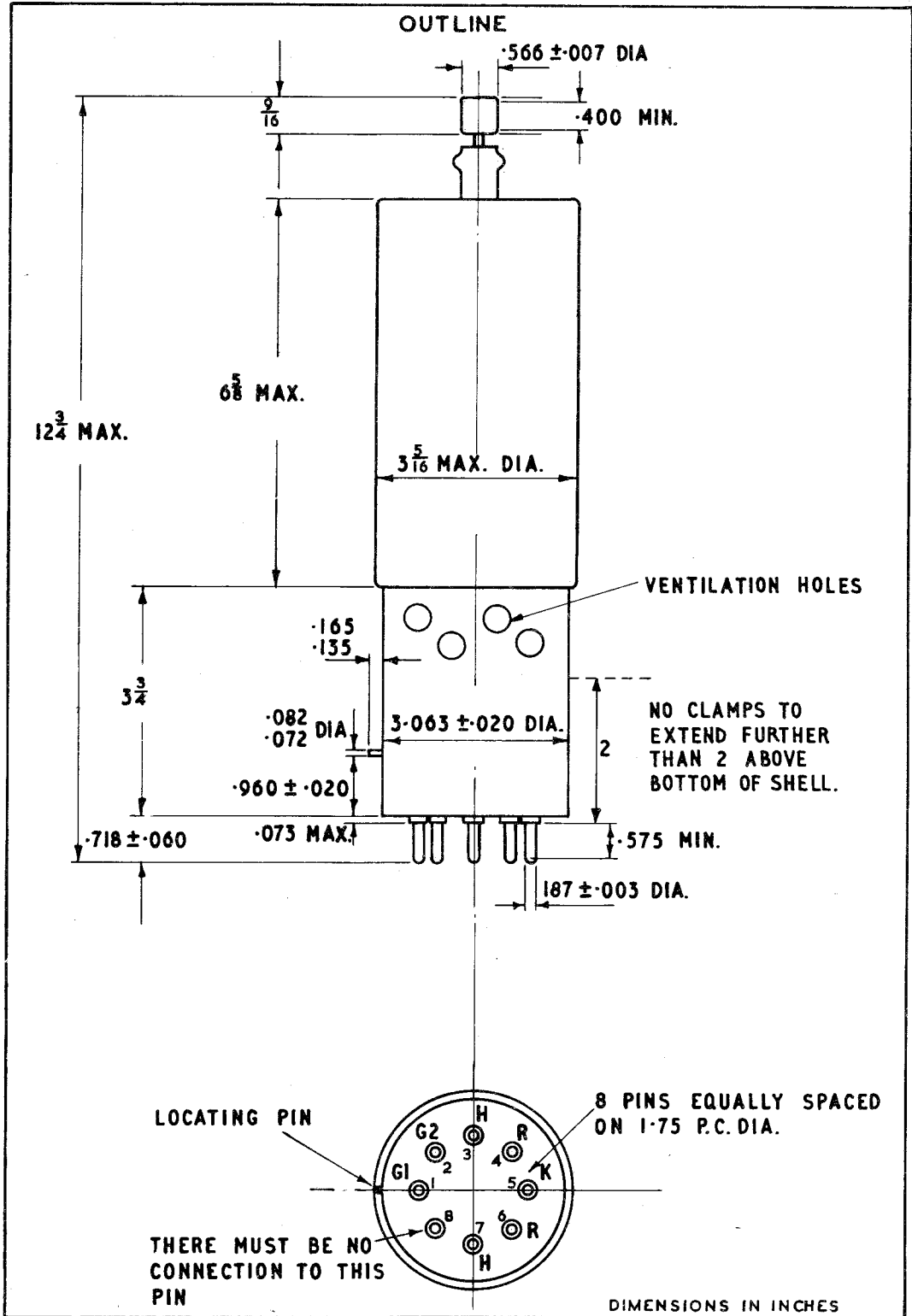

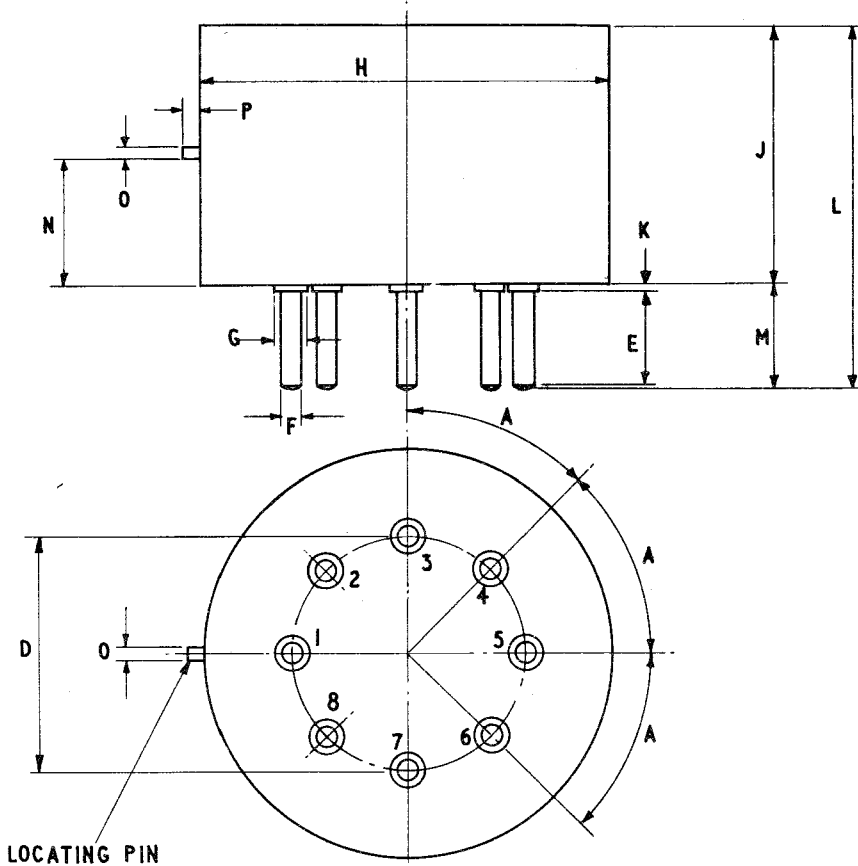

LOCATING PIN

	INCHES			DEGREES 45
	MIN.	NOM.	MAX.	
A				
D		1.75		
E	0.575			
F	0.184	0.187	0.190	
G			0.260	
H	3.042	3.062	3.082	
J		3.75		
K			0.073	
L		4.5		
M			0.718	
N	.94	.96	.98	
O	.072		0.082	
P	0.135	0.150	0.165	

ALSO ALLOW
ADDITIONAL
.060 FOR SOLDER.

BASE FOR VX 4151, CV5466.